



**Manufacture.**

**Merry-Brand, Hand Tool &**

**Nile-Brand, Pneumatic Tools**

**MUROMOTO TEKKO CO., LTD.**

Head Office

1-8-1, Shodai Tajika, Hirakata-shi, Osaka, 573-1132, Japan

Tel. +81-72-850-0091 / Fax. +81-72-850-0082

E-mail: [mrt.info-f@muromoto.co.jp](mailto:mrt.info-f@muromoto.co.jp)

---

AGENT

**Make advances!  
"NILE" BRAND AIR TOOLS!**

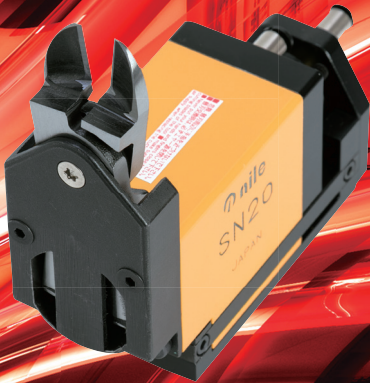
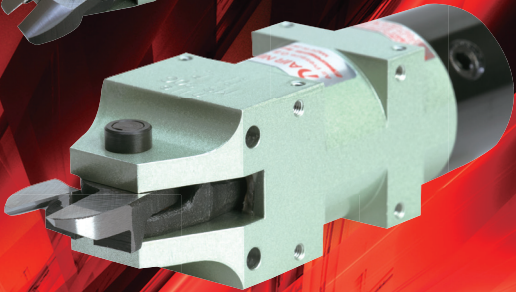

**nile air tools**

**Professional tools!  
"MERRY" BRAND HAND TOOLS!**

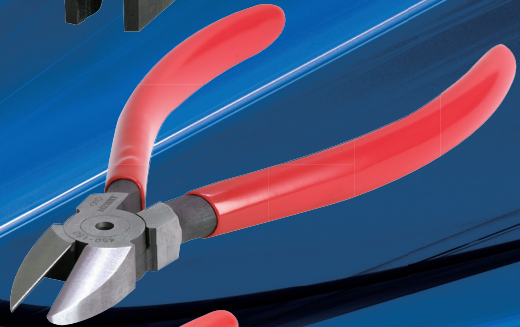

**MERRY**



## ***Technical capabilities and achievements***

Our "Merry" brand has a history of 90 years and "NILE" brand has a history of 50 years.  
We have been producing various work tools and air tools until now.

Even a piece of any type of specialized blade can be designed and manufactured to meet your particular application, so we received a favorable reception from many customers so far.

We will continue to provide high-value-added products aim to further technological upgrading high-precision, high-quality, of workers in the future.



**nile air tools**  
*Make advances!*  
**"NILE" BRAND  
 AIR TOOLS!**

**MODEL NUMBER INDEX 93P**

BLADE	<b>04</b>
AIR CUTTERS (HAND-HELD TYPE)	<b>10</b>
AIR CUTTERS (MACHINE-FITTING TYPE)	<b>13</b>
SQUARE AIR CUTTERS	<b>17</b>
VERTICAL TYPE AIR CUTTERS / SLIDING AIR CUTTERS	<b>22</b>
SN TYPE SLIDING AIR CUTTERS	<b>24</b>
SLIDE & CUT AIR CUTTERS	<b>28</b>
STAND-HOLDER / FOOT VALVE / TIMING UNIT	<b>30</b>
AIR HEAT CUTTERS	<b>33</b>
AIR SHOT-HAMMER	<b>36</b>
AIR SHEARS / AIR PLATE SHEARS / AIR MULTI-PURPOSE SCISSORS	<b>38</b>
AIR FIL-SAWS	<b>41</b>
MINI BELTERS / AIR SQUEEZERS / CABLE CUTTERS / AIR TWISTER	<b>43</b>
CABLE STRIPPERS	<b>46</b>
CURL HOSE	<b>50</b>



**MERRY**  
*Professional tools!*  
**"MERRY" BRAND  
 HAND TOOLS!**

**MODEL NUMBER INDEX 93P**

SIDE CUTTING PLIERS	<b>54</b>
NIPPERS	<b>57</b>
NIPPERS FOR PIANO WIRE	<b>61</b>
LONG NOSE SIDE CUTTING PLIERS & PLIERS	<b>63</b>
NIPPERS FOR CUTTING PLASTICS 160S SERIES	<b>66</b>
NIPPERS FOR CUTTING PLASTICS HOT SELLER	<b>68</b>
END CUTTING PLASTICS NIPPERS / R-CUT NIPPERS FOR CUTTING PLASTICS	<b>71</b>
NIPPERS FOR CUTTING PLASTICS OTHERS	<b>73</b>
HEAT NIPPERS FOR CUTTING PLASTICS	<b>75</b>
SERIES THING	<b>78</b>
CLIP PLIERS / SNAP RING PLIERS / DUCT CUTTERS	<b>81</b>
PLASTIC PIPE CUTTERS	<b>83</b>
DUCT AND MOULD CUTTERS / MERRY CUTTERS	<b>86</b>
STRIPPERS	<b>89</b>
OTHERS	<b>91</b>

# ATTENTION !!

Before using the tools, observe the following general notes and read operation manual carefully for safety and correct operation.

## “ NILE ” AIR TOOLS



- Keep air supply closed always while the tools are out of service for inspection, replacement of cutting blade and after use.



- As the air tools deliver extreme cutting and pressing power, NEVER touch the cutting blades or put the hands/fingers close to the cutting blade.
- Make sure to use safety glasses when operating the tools to protect operators eyes from flying cat pieces.
- Employ the recommended air pressure for operation. Higher air pressure will cause various troubles of the tools.

## “ MERRY ” HAND TOOLS



- Do not apply the tools to cut unsuitable subjects. Unsuitable application of the tools will cause damage of the cutting blades and flying pieces of the broken pieces of the cutting blades.



- The cutting blades have very sharp cutting edges. Never touch the cutting blades or put the hands/fingers close to the cutting blades.
- Make sure to use safety glasses when operating the tools.

**IN ADDITION, STRICTLY OBSERVE YOUR LOCAL SAFETY REGULATIONS FOR CUTTING EQUIPMENTS.**

## NOTES TO USERS

Before using the tools, you should first thoroughly read the following warnings and cautions for safety and correct operation. In addition, observe strictly all your local safety regulations for cutting tools and related equipments.



### WARNINGS:

#### Working conditions for air tools

1. **Air pressure** : Supply recommended air pressure by using pressure gauges and control valves. Higher air pressure will cause damages and accidents.
2. **Power source** : Use only air compressed by air compressors. Do not use any other power source, such as high pressure gas of oxygen, acetylene, propane, etc. which will cause explosive hazard.
3. **Air hose** : Use air hoses of proper size and quality to suit the tools and application. Air hoses should be oil-proof and abrasion-proof in quality. Do not use old and decrepit air hoses. Do not use excessively long air hose of more than 5M.
4. **Fittings for air hose** : Attach and fix all fittings securely to air hoses and air tools. Accidentally disconnected air hose, caused by imperfect fixing, flies around to cause hazard.

#### Working environment

1. **Keep working places sufficiently bright, clean and ordered** : Dark and/or disordered working places may cause accident.
2. **Never use air tools in or near any inflammable and explosive goods or environment.**

#### Working wear

1. **Put on proper and perfect-fitting working wear** : Do not put on loose or imperfect wear and such ornaments as necklaces. Put on working caps to set long hair off the tools.
2. **Use proper protective guards** such as helmets, safety glasses, earplugs, dust-proof masks, safety shoes, etc. to meet each job.



### CAUTIONS:

#### Essential cautions for use of air tools

1. Pay full attention for safety operation of the air tools without rashly or thoughtless action.
2. Do not allow any out-of-duty persons, especially children, come close to the working place.
3. Use the air tools within the rated capacity. Over-loaded operation will cause damage and trouble of air tools.
4. Exhaust air should be directed not to hit eyes and years of persons around the working area.
5. Handle the air tools carefully without abuse. Shock given to air tools by throwing or dropping on the floor may cause accident or trouble.
6. Handle the air hose carefully. Do not use the air hose for the purpose of supporting or carrying air tools. Failed/damaged air hose will cause accident.
7. Pay sufficient care for air tools not in use. Store air tools, after maintaining properly, in a dried and out of reach of children place.

#### Use of air tools

1. **Securely fix the subject to work for with air tools.** Insufficiently-fixed work pieces may fly off to cause personal injury or material damage. **Do not put fingers/ hands or cloth near to cutting blades or any other activating parts or accessories of air tools. Do not operate air tools in an irrational/ unjustifiable physical posture.** Hold the tools securely and keep a stabilized working body balance. **Do not make sudden start of operation. Make sure if the throttle valve of air tools is shut off when connecting to air hoses. Keep the throttle lever of air tools off while carrying the tools by hands. Do not make air tools contact electricity.** Air tools are not insulated. **Stop operation of air tools immediately when feeling any irregularity.** Have the tools checked carefully and repaired properly.
2. **Apply air tools only to recommended applications.** Never use air tools for unsuitable purpose / application out of prescribed recommendations.
3. **Never make any modification of air tools by yourself.** The tools modified will cause accident.
4. **Do not remove any integrated parts off air tools.** Using air tools with any parts removed off may cause accident.
5. **Shut off air supply and disconnect air tools from the air hose when air tools are kept out of use.** when exchanging the attachments (cutting blades, files, saw blades, etc.), when the air tools are under maintenance service, and whenever any danger is anticipated.

#### Maintenance, inspection and repair

1. Never forget to check air tools before using. make sure if all assembling screws and parts are well set and not damaged. Loosen screws and imperfect parts may cause lowered tool performance or accident.
2. Do not neglect to perform regular maintenance and inspection of air tools. Safety and effective use of the air tools is assured by regular maintenance and inspection practice.
3. Ask us direct or our authorized servicing centers for repair of air tools. We shall be free from liability for any accident or problem caused by repair or treatment of air tools made by any others.

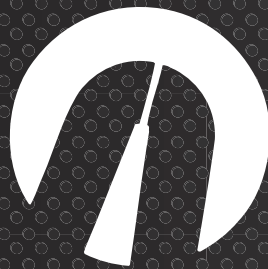

**MUROMO**  
"NILE" BRAND  
AIR TOOLS



**nile air tools**

AIR CUTTERS (HAND-HELD TYPE)  
AIR CUTTERS (MACHINE-FITTING TYPE)  
SQUARE AIR CUTTERS  
VERTICAL TYPE AIR CUTTERS / SLIDING AIR CUTTERS  
SN TYPE SLIDING AIR CUTTERS  
SLIDE & CUT AIR CUTTERS  
STAND-HOLDER / FOOT VALVE / TIMING UNIT  
AIR HEAT CUTTERS  
AIR SHOT-HAMMER  
AIR SHEARS / AIR PLATE SHEARS / AIR MULTI-PURPOSE SCISSORS  
AIR FIL-SAWS  
MINI BELTERS / AIR SQUEEZERS / CABLE CUTTERS / AIR TWISTER  
CABLE STRIPPERS  
CURL HOSE



nile air tools

# BLADE



# BLADE

Section of blade

Single blade

Standard

Full-flush round type

Full-flush flat type

## S Type

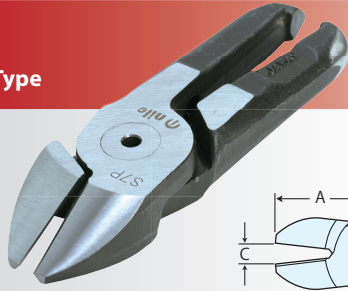

Standard Blades

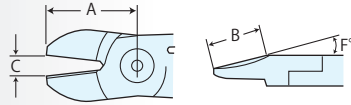

Model	Dimensions (mm)				Section of blade
	A	B	C	F°	
S20	24.0	12.0	2.5	25	Single blade
S2	24.0	12.0	3.0	25	Single blade
S4	27.0	14.0	5.0	25	Single blade
S5A	35.0	17.0	5.5	30	Single blade
S5	35.0	17.0	7.0	30	Single blade
S250	43.0	20.0	10.0	15	Single blade
S7P1	43.0	20.0	7.0	30	Single blade
S9P1	65.0	38.0	12.0	15	Single blade
S7P	43.0	20.0	7.0	30	Single blade
S9P	66.0	38.0	16.0	15	Single blade
S120	45.0	22.0	9.0	35	Standard

## CR Type

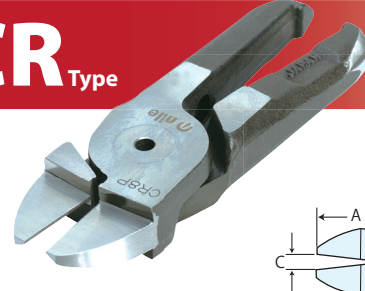

Clipper edge

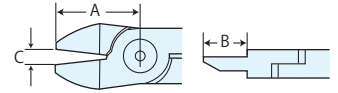

Model	Dimensions (mm)			Section of blade
	A	B	C	
CR20	24.0	13.0	2.5	Single blade
CR2	24.0	13.0	3.0	Single blade
CR4	27.0	12.5	4.5	Single blade
CR6A	35.0	18.0	5.0	Single blade
CR6	35.0	18.0	7.0	Single blade
CR250	43.0	22.0	11.0	Single blade
CR8P1	43.0	23.0	7.0	Single blade
CR8P	43.0	23.0	7.0	Single blade
CR120	60.0	35.0	11.0	Standard

## S-S Type

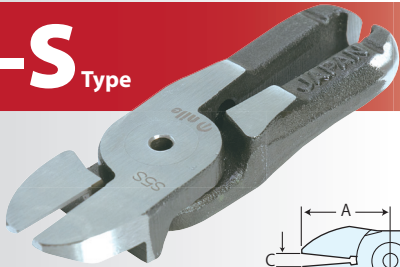

Flat surface

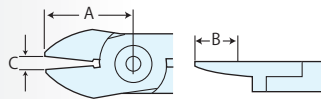

Model	Dimensions (mm)			Section of blade
	A	B	C	
S20S	24.0	12.0	2.5	Single blade
S2S	24.0	12.0	3.0	Single blade
S4S	27.0	13.0	5.0	Single blade
S5AS	35.0	17.0	5.5	Single blade
S5S	35.0	17.0	7.0	Single blade
S250S	43.0	23.0	10.0	Single blade
S7P1S	43.0	22.0	7.0	Single blade
S7PS	43.0	20.0	7.0	Single blade
S9PS	66.0	37.0	16.0	Single blade
S120S	55.0	30.0	10.0	Standard

## EP Type

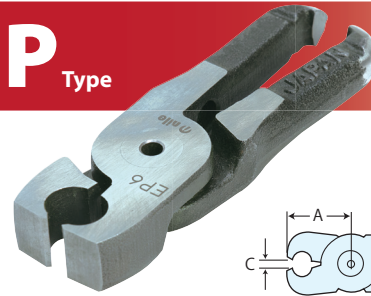

End cutting edge

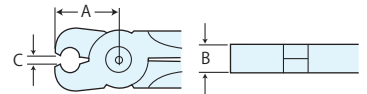

Model	Dimensions (mm)			Section of blade
	A	B	C	
EP20	20.0	7.0	2.0	Standard
EP2	20.0	7.0	2.5	Standard
EP4	26.0	9.0	4.5	Standard
EP6A	28.0	12.0	4.5	Standard
EP6	28.0	12.0	5.5	Standard
EP10P1	34.0	17.0	5.5	Standard
EP10P	34.0	17.0	5.5	Standard
EP120	40.0	25.0	8.0	Standard

## P Type



Heavy-duty

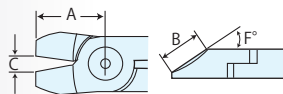

Model	Dimensions (mm)				Section of blade
	A	B	C	F°	
P6A	29.0	12.0	4.5	35	Single blade
P6	29.0	11.0	6.0	35	Standard
P8P1	37.0	12.0	5.0	25	Standard
P8P1S	37.0	15.0	5.0	-	Standard
P8P	37.0	12.0	6.0	25	Standard
P8PS	37.0	12.0	6.0	-	Standard
P120	40.0	16.0	8.0	35	Standard

## Z Type

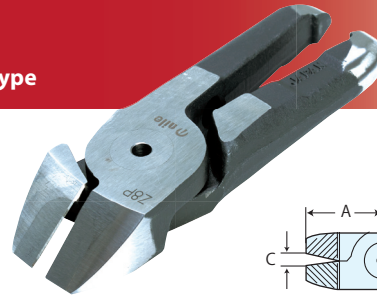

Carbide tipped for hard wire

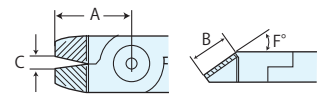

Model	Dimensions (mm)				Section of blade
	A	B	C	F°	
Z20	24.0	11.0	2.5	25	Single blade
Z2	24.0	11.0	3.0	25	Single blade
Z4	27.0	10.0	5.0	25	Single blade
Z6A	30.0	15.0	5.0	35	Standard
Z6	30.0	15.0	6.0	35	Standard
Z8P1	38.0	20.0	5.0	40	Standard
Z57P	43.0	20.0	7.0	30	Standard
Z8P	38.0	20.0	6.0	40	Standard
Z120	40.0	17.0	7.0	35	Standard



# BLADE

Section of blade

Single blade

Standard

Full-flush round type

Full-flush flat type

## Z-S Type

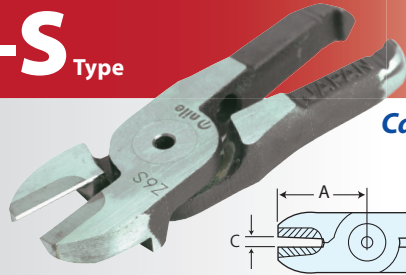

Carbide tipped for hard wire

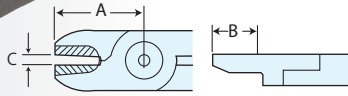

Model	Dimensions (mm)			Section of blade
	A	B	C	
Z20S	24.0	11.0	2.5	Single blade
Z2S	24.0	11.0	3.0	Single blade
ZT7S	27.0	11.0	3.5	Single blade
Z4S	27.0	11.0	5.0	Single blade
Z6AS	34.0	16.0	6.0	Standard
Z6JS	34.0	16.0	5.0	Standard
Z6S	34.0	16.0	7.0	Standard
ZS7PS	43.0	17.0	7.0	Standard
Z8PS	40.0	20.0	7.0	Standard
Z120S	40.0	17.0	7.0	Standard

## F Type

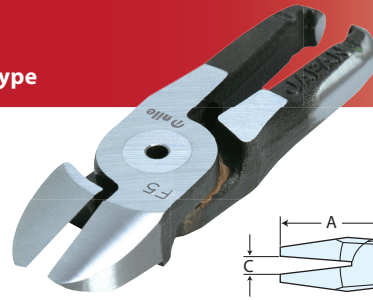

Plastic edge

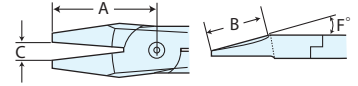

Model	Dimensions (mm)				Section of blade
	A	B	C	F°	
F10	24.0	12.0	2.5	15	Full-flush round type
F1	24.0	12.0	3.0	15	Full-flush round type
FT7	27.0	12.0	3.5	25	Full-flush round type
F3	27.0	12.0	5.0	25	Full-flush round type
F5A	35.0	15.0	5.5	15	Full-flush round type
F5J	34.0	15.0	5.0	15	Full-flush round type
F5	35.0	15.0	8.5	15	Full-flush round type
F250	43.0	22.0	13.0	15	Full-flush round type
F9P1	66.0	38.0	10.5	15	Full-flush round type
F9P	66.0	38.0	16.0	15	Full-flush round type
F9PF	66.0	38.0	30.0	15	Full-flush round type
F120	53.0	35.0	12.0	30	Full-flush round type

## ZCR Type

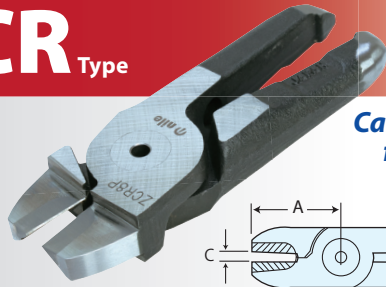

Carbide tipped for hard wire

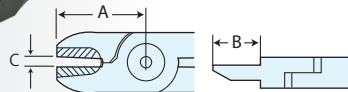

Model	Dimensions (mm)			Section of blade
	A	B	C	
ZCR20	24.0	10.0	2.5	Single blade
ZCR2	24.0	10.0	3.0	Single blade
ZCR7	26.0	10.0	3.5	Single blade
ZCR4	27.0	10.0	5.0	Single blade
ZCR6A	35.0	16.0	7.0	Standard
ZCR6J	35.0	16.0	5.0	Standard
ZCR6	35.0	16.0	7.0	Standard
ZCR8P1	38.0	16.0	6.0	Standard
ZCR8P	38.0	16.0	7.0	Standard
ZCR120	40.0	16.0	7.0	Standard

## F-S Type

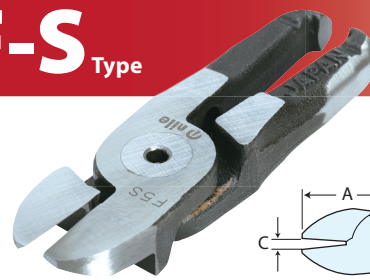

Flat surface for plastic

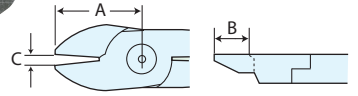

Model	Dimensions (mm)			Section of blade
	A	B	C	
F10S	24.0	12.0	2.5	Full-flush flat type
F1S	24.0	12.0	3.0	Full-flush flat type
FT7S	27.0	12.0	3.5	Full-flush flat type
F3S	27.0	12.0	5.0	Full-flush flat type
F3LS	50.0	30.0	8.0	Full-flush flat type
F5AS	35.0	16.0	5.5	Full-flush flat type
F5JS	35.0	17.0	5.0	Full-flush flat type
F5S	35.0	16.0	8.5	Full-flush flat type
F5LS	65.0	37.0	15.0	Full-flush flat type
F250S	43.0	23.0	13.0	Full-flush flat type
F9P1S	66.0	39.0	10.5	Full-flush flat type
F9PS	66.0	37.0	16.0	Full-flush flat type

## ZEP Type

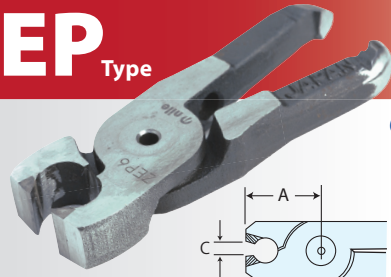

Carbide tipped for hard wire

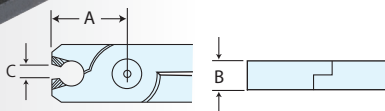

Model	Dimensions (mm)			Section of blade
	A	B	C	
ZEP20	20.0	7.0	2.0	Standard
ZEP2	20.0	7.0	2.5	Standard
ZEP7	26.0	9.0	3.0	Standard
ZEP4	26.0	9.0	4.5	Standard
ZEP6A	28.0	12.0	5.0	Standard
ZEP6J	28.0	12.0	4.0	Standard
ZEP6	28.0	12.0	6.0	Standard
ZEP10P1	34.0	17.0	5.5	Standard
ZEP10P	34.0	17.0	5.5	Standard
ZEP120	40.0	25.0	8.0	Standard

## FD Type

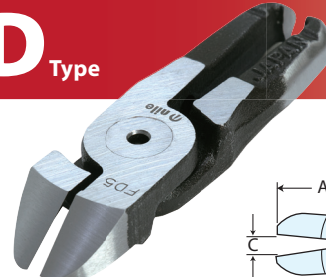

Level cutting for plastic

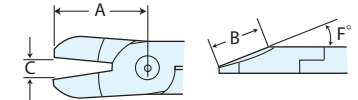

Model	Dimensions (mm)				Section of blade
	A	B	C	F°	
FD10	24.0	10.0	2.5	40	Full-flush round type
FD1	24.0	10.0	3.0	40	Full-flush round type
FD7	27.0	10.0	3.5	40	Full-flush round type
FD3	27.0	10.0	4.5	40	Full-flush round type
FD5A	35.0	14.0	5.5	40	Full-flush round type
FD5J	34.0	14.0	5.0	40	Full-flush round type
FD5	35.0	14.0	8.5	40	Full-flush round type
FD250	43.0	15.0	13.0	40	Full-flush round type
FD9P1	59.0	27.0	9.0	30	Full-flush round type
FD9P	59.0	27.0	14.0	30	Full-flush round type
FD9PF	59.0	27.0	26.0	30	Full-flush round type

# BLADE

Section of blade

Single blade

Standard

Full-flush round type

Full-flush flat type

## FEP Type

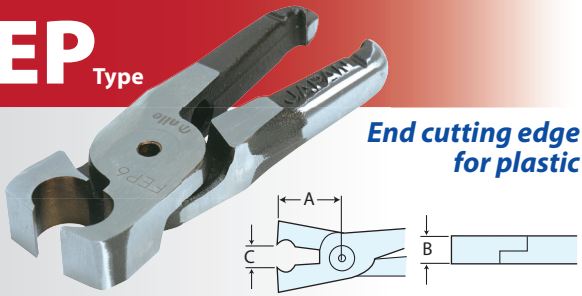

Model	Dimensions (mm)			Section of blade
	A	B	C	
FEP20	20.0	7.0	2.0	Full-flush round type
FEP2	20.0	7.0	2.5	Full-flush round type
FEP7	26.0	9.0	3.0	Full-flush round type
FEP4	26.0	9.0	4.5	Full-flush round type
FEP6A	28.0	12.0	4.0	Full-flush round type
FEP6	28.0	12.0	8.5	Full-flush round type
FEP10P1	33.0	17.0	6.0	Full-flush round type
FEP10P	34.0	17.0	8.0	Full-flush round type

## SY Type

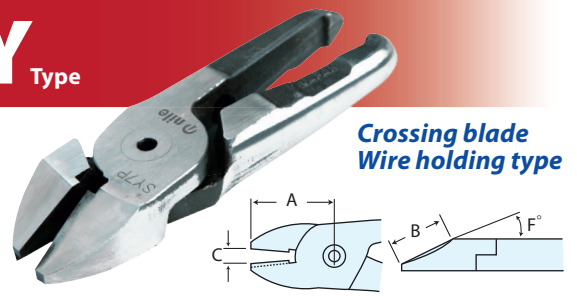

Model	Dimensions (mm)				Section of blade
	A	B	C	F°	
SY7P	43.0	18.0	8.0	30	others

## SH Type

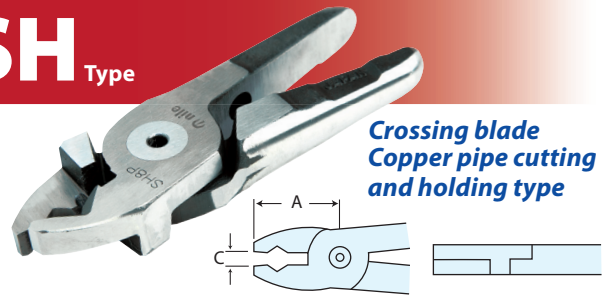

Model	Dimensions (mm)				Section of blade
	A	B	C	F°	
SH8P	43.0	-	7.0	-	others

## Y Type

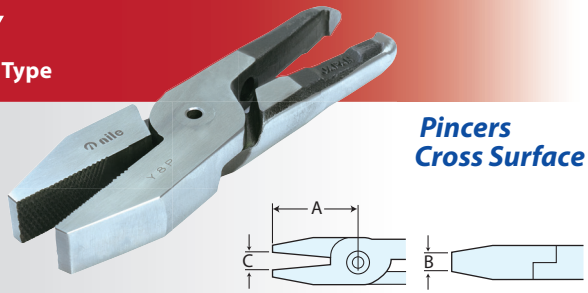

Model	Dimensions (mm)		
	A	B	C
Y20	24.0	7.0	2.5
Y2	24.0	7.0	3.0
YT7	27.0	9.0	4.0
Y4	27.0	9.0	5.0
Y6A	47.0	6.0	9.0
Y6J	47.0	6.0	6.0
Y6	47.0	6.0	10.0
Y250	45.0	12.0	14.0
Y8P1	70.0	17.0	12.5
Y8P	70.0	17.0	16.0
Y817P	65.0	17.0	16.0
Y120	60.0	25.0	13.0

## A Type

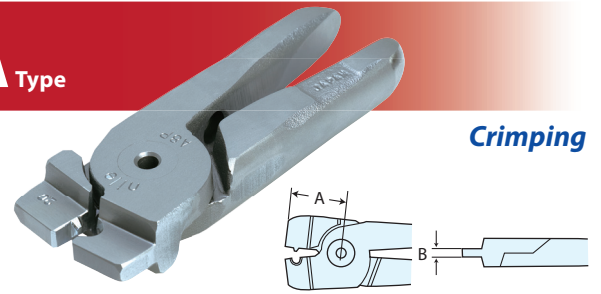

Model	Dimensions (mm)	
	A	B
A8P1-1.25	30.0	5.8
A8P1-2.0	30.0	5.8
A8P-1.25	30.0	5.8
A8P-2.0	30.0	5.8
A8P-5.5	32.0	5.8
A8WP-1.25-2.0	39.5	5.8
A8WP-2.0-5.5	39.0	6.0

## K Type

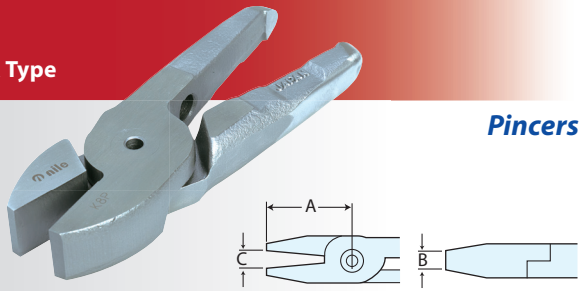

Model	Dimensions (mm)		
	A	B	C
K6A	35.0	12.0	5.5
K6J	35.0	12.0	5.0
K6	35.0	12.0	7.0
K8P1	43.0	17.0	7.0
K8P	43.0	17.0	10.0

## AR Type

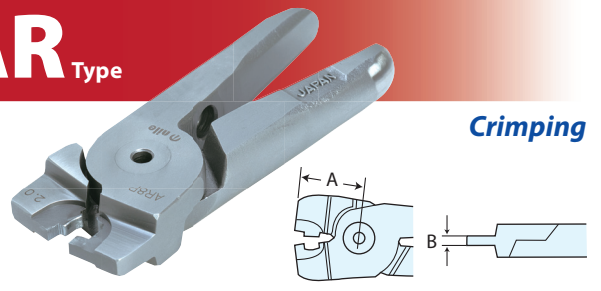



Model	Dimensions (mm)	
	A	B
AR8P1-1.25	31.5	6.5
AR8P1-2.0	32.5	6.5
AR8P-1.25	31.5	6.5
AR8P-2.0	32.5	7.0
AR8P-5.5	34.5	6.5
AR8WP-1.25-2.0	38.5	6.5
AR8WP-2.0-5.5	40.0	6.5

# BLADE

## Cutting capacity List

Model	For copper wire		For steel wire		For soft plastics		For piano wire	
	Diameter (φmm)	Blade	Diameter (φmm)	Blade	Diameter (φmm)	Blade	Diameter (φmm)	Blade
MR3	0.8	S20	-	-	1.0	F10	-	-
MR5	1.0	S2	-	-	2.0	F1	0.3	Z2
MR10	1.6	S4	1.0	S4	4.0	F3	0.5	Z4
MR20	2.6	S5	2.0	P6	7.0	F5	1.0	Z6
MP25	-	-	-	-	8.0	F250	-	-
MP25A	2.6	S5	2.0	P6	-	-	-	-
MR30A	3.3	S7P	2.8	P8P	10.0	F9P	1.2	Z8P
MP250	4.0	S7P1	3.2	P8P1	-	-	-	-
MP35A	4.8	S7P	4.0	P8P	13.0	F9P	-	-
MR50FK	-	-	-	-	12.0	F9PF	-	-
MR50AK	5.5	P120	4.5	P120	-	-	1.6	Z120
MP55AK	7.0	P120	6.0	P120	-	-	2.0	Z120

Model	For stainless wire		※For hard plastics	
	Diameter (φmm)	Blade	Diameter (φmm)	Blade
MR3	-	-	-	-
MR5	-	-	1.0	F1
MR10	-	-	2.6	F3
MR20	1.6	P6	5.0	F5
MP25	-	-	-	-
MP25A	1.6	P6	-	-
MR30A	2.0	P8P	6.5	F9P
MP250	2.3	P8P1	-	-
MP35A	2.8	P8P	-	-
MR50FK	-	-	-	-
MR50AK	3.5	Z120	-	-
MP55AK	4.3	Z120	-	-

Shape of terminals	Size (sq)	Model&Blade
 Ring terminals	1.25	MR30A/A8P-1.25
	2.0	MR30A/A8P-2.0
	5.5	MP35A/A8P-5.5
 Insulated connectors	1.25	MR30A/AR8P-1.25
	2.0	MR30A/AR8P-2.0
	5.5	MP35A/AR8P-5.5

※ Bakelite, polyacetal acrylic resin etc.

## SPECIAL BLADES

The dimensions (A,B,C,D&R) are required for designing and quoting special blades such as below illustrated.

B:length of edge R:radius D:angle

### 1 "L" shape blade

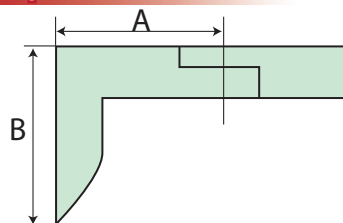

### 2 Crank shape blade

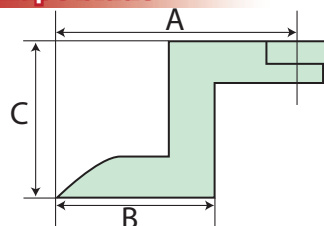

### 3 Radius cutting blade

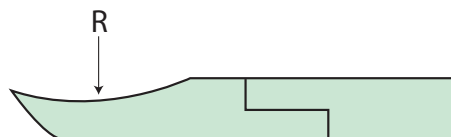

### 4 "L" shape end cutting blade

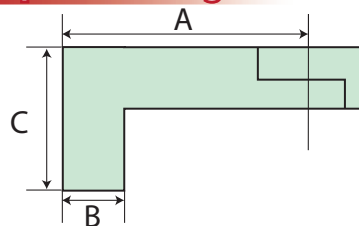

### 5 Long nose blade

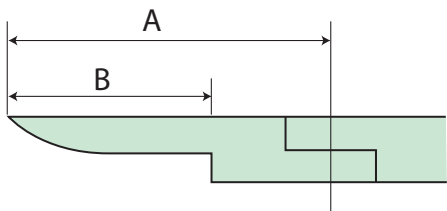

※

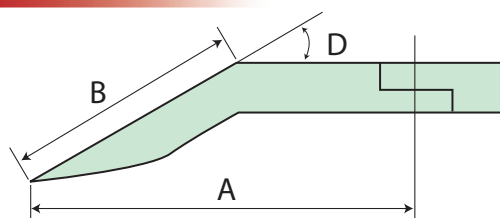

# BLADE

## SPECIAL BLADES

### Some examples of custom-made blades

(Designed to meet your particular application.)

Even a piece of any type of special blade can be designed and manufactured to meet your particular application.

Samples of actual work pieces are required on inquiry for designing and quoting.

#### 1 Plastics cutting

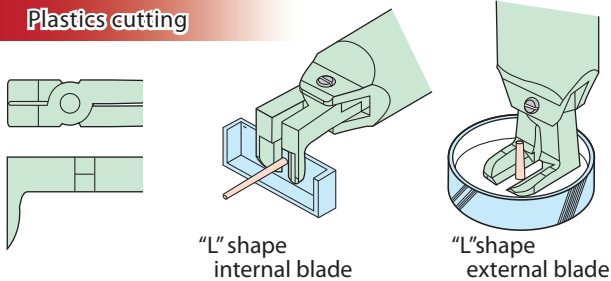

#### 2 Plastics cutting

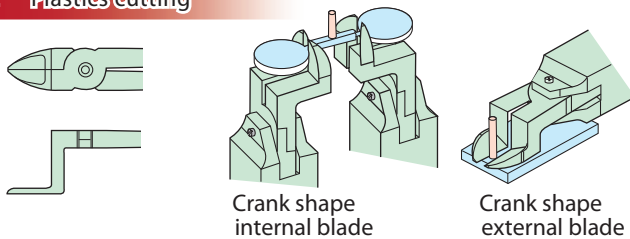

#### 3 Radius cutting of plastics

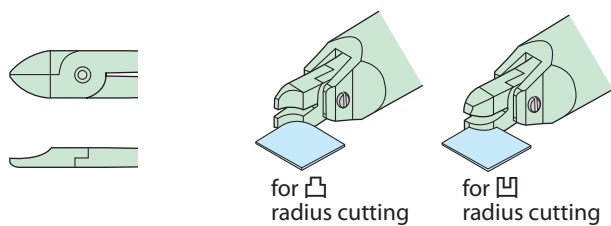

#### 4 Plastics cutting

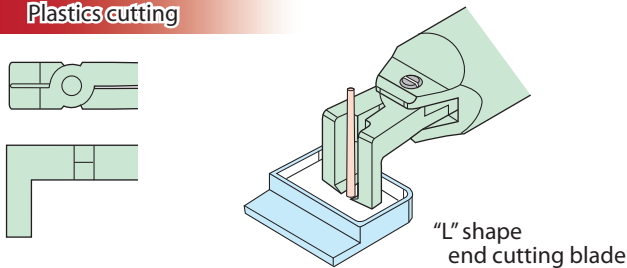

#### 5 Plastics cutting

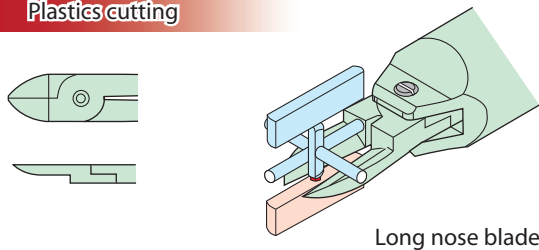

#### 6 Pressing

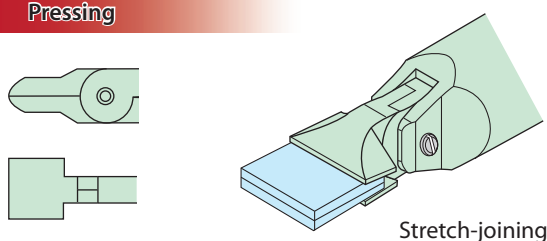

#### 7 Punching various holes

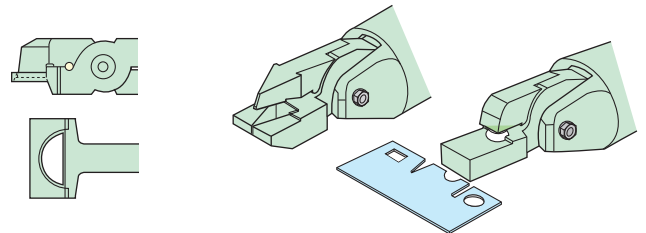

#### 8 Sash caulking

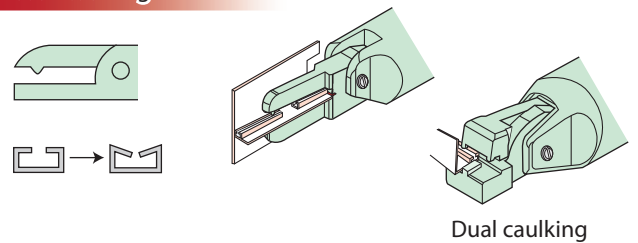

#### 9 Caulking

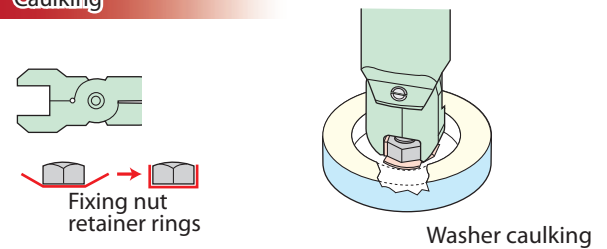

#### 10 Crashing

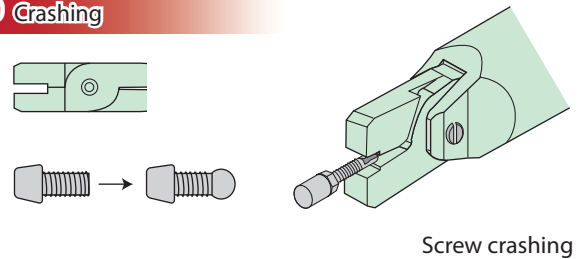

#### 11 Pinching

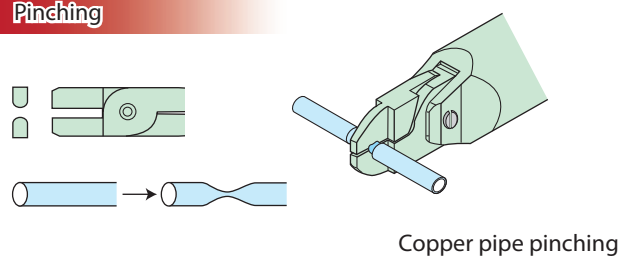

#### 12 Bending

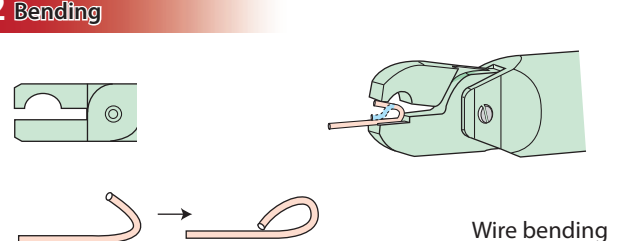



nile air tools

# AIR CUTTERS

HAND-HELD TYPE



# AIR CUTTERS (HAND-HELD TYPE)

## HAND-HELD TYPE

### MR Type

Standard

### MP Type

Heavy-duty

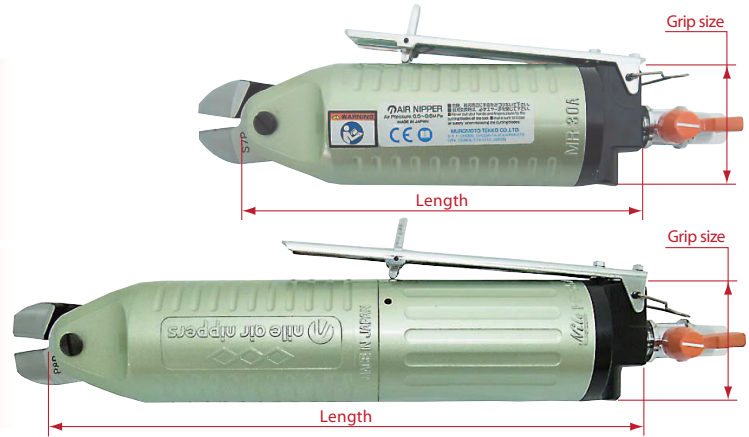

#### MR type specification

Model (less blade)	Length (mm)	Weight (g)	Grip size $\phi$ (mm)	Air consumption (cm <sup>3</sup> /stroke)	Power N (approx.)	Air pressure (MPa)
MR3	112	90	20	31	773	0.4~0.5
MR5	104	130	30	41	842	0.4~0.5
MR10	124	200	36	105	1,493	0.4~0.5
MR20	155	340	45	268	3,490	0.5~0.6
MR30A	191	520	56	631	5,531	0.5~0.6
MR50FK	198	1,170	75	1,212	3,514	0.5~0.6
MR50AK	237	1,290	75	1,285	12,060	0.5~0.6

#### MP type specification

Model (less blade)	Length (mm)	Weight (g)	Grip size $\phi$ (mm)	Air consumption (cm <sup>3</sup> /stroke)	Power N (approx.)	Air pressure (MPa)
MP3	173	120	20	48	1,090	0.3~0.4
MP5	154	200	30	68	1,234	0.3~0.4
MP10	195.5	300	36	171	2,099	0.3~0.4
MP25	204	480	45	405	2,359	0.5~0.6
MP250	250	560	45	624	6,071	0.5~0.6
MP25A	242	560	45	459	5,373	0.4~0.5
MP35A	283	830	56	1,146	10,118	0.5~0.6
MP55AK	370	2,000	75	2,569	23,026	0.5~0.6

#### MR type Blade cutting capacity

Model	Blade (*) Carbide tipped	Copper wire	Steel wire	Stainless wire	Piano wire	Crimping	Plastic	
							Soft	Hard
MR3	S20, S20S, CR20, EP20	0.8	0.4	-	-	-	-	-
	Z20*, Z20S, ZCR20, ZEP20	0.8	0.4	0.2	0.2	-	-	-
	F10, F10S, FD10, FEP20	-	-	-	-	-	1.0	-
MR5	S2, S2S, CR2, EP2	1.0	0.5	-	-	-	-	-
	Z2*, Z2S, ZCR2, ZEP2	1.0	0.5	0.3	0.3	-	-	-
	F1, F1S, FD1, FEP2	-	-	-	-	-	2.0	-
MR10	S4, S4S, CR4, EP4	1.6	1.0	-	-	-	-	-
	Z4*, Z4S, ZCR4, ZEP4	1.6	1.0	0.5	0.5	-	-	-
	F3, F3S, FD3, F3LS, FEP4	-	-	-	-	-	4.0	2.6
	Y4	-	-	-	-	-	-	-
MR20	S5, S5S, P6, CR6, EP6	2.6	2.0	1.6	-	-	-	-
	Z6*, Z6S, ZCR6, ZEP6	2.6	2.0	1.6	1.0	-	-	-
	F5, F5S, FD5, F5LS, FEP6	-	-	-	-	-	7.0	5.0
MR30A	Y6, K6	-	-	-	-	-	-	-
	S7P, S7PS, P8P, CR8P, EP10P, P8PS	3.3	2.8	2.0	-	-	-	-
	Z8P*, Z8PS, ZCR8P, ZEP10P	3.3	2.8	2.0	1.2	-	-	-
	F9P, F9PS, FD9P, FEP10P	-	-	-	-	-	10.0	6.5
	Y8P, K8P, Y817P	-	-	-	-	-	-	-
MR50FK	SH8P	-	-	-	-	-	-	-
	A8P-1.25, A8P-2.0	-	-	-	-	1.25/2.0	-	-
	AR8P-1.25, AR8P-2.0	-	-	-	-	1.25/2.0	-	-
MR50AK	F9PF, FD9PF	-	-	-	-	-	12.0	6.5
	S120, S120S, P120, CR120, EP120	5.5	4.5	3.5	-	-	-	-
	Z120*, Z120S, ZCR120, ZEP120	5.5	4.5	3.5	1.6	-	-	-
Y120	-	-	-	-	-	-	-	

#### MP type Blade cutting capacity

Model	Blade (*) Carbide tipped	Copper wire	Steel wire	Stainless wire	Piano wire	Crimping	Plastic	
							Soft	Hard
MP3	S20, S20S, CR20, EP20	0.8	0.4	-	-	-	-	-
	Z20*, Z20S, ZCR20, ZEP20	0.8	0.4	0.2	0.2	-	-	-
	F10, F10S, FD10, FEP20	-	-	-	-	-	1.0	-
MP5	S2, S2S, CR2, EP2	1.0	0.5	-	-	-	-	-
	Z2*, Z2S, ZCR2, ZEP2	1.0	0.5	0.3	0.3	-	-	-
	F1, F1S, FD1, FEP2	-	-	-	-	-	2.0	-
MP10	S4, S4S, CR4, EP4	1.6	1.0	-	-	-	-	-
	Z4*, Z4S, ZCR4, ZEP4	1.6	1.0	0.5	0.5	-	-	-
	F3, F3S, FD3, F3LS, FEP4	-	-	-	-	-	4.0	2.6
	Y4	-	-	-	-	-	-	-
MP25	S250, S250S, CR250	2.4	1.8	-	-	-	-	-
	F250, F250S, FD250	-	-	-	-	-	8.0	5.0
MP250	S7P1, S7P1S, P8P1, CR8P1, EP10P1	4.0	3.2	-	-	-	-	-
	Z8P1*, ZCR8P1, ZEP10P1	4.0	3.2	2.3	1.2	-	-	-
	F9P1, FD9P1, F9P1S	-	-	-	-	-	8.0	6.5
MP25A	S5, S5S, P6, CR6, EP6	2.6	2.0	1.6	-	-	-	-
	Z6*, Z6S, ZCR6, ZEP6	2.6	2.0	1.6	1.0	-	-	-
	F5, F5S, FD5, F5LS, FEP6	-	-	-	-	-	7.0	5.0
MP35A	Y6, K6	-	-	-	-	-	-	-
	S7P, P8P, S7PS, CR8P, EP10P, P8PS	4.8	4.0	2.8	-	-	-	-
	Z8P*, Z8PS, ZCR8P, ZEP10P	4.8	4.0	2.8	1.2	-	-	-
MP55AK	F9P, F9PS, FD9P, FEP10P	-	-	-	-	-	13.0	6.5
	Y8P, K8P, Y817P, SH8P	-	-	-	-	-	-	-
	A8P-1.25/2.0/5.5, A8WP-1.25-2.0/2.0-5.5	-	-	-	-	-	1.25/20/55	-
AR8P-1.25/2.0/5.5, AR8WP-1.25-2.0/2.0-5.5	-	-	-	-	-	1.25/20/55	-	
MP55AK	S120, S120S, P120, CR120, EP120	7.0	6.0	4.3	-	-	-	-
	Z120*, Z120S, ZCR120, ZEP120	7.0	6.0	4.3	2.0	-	-	-
	F120	-	-	-	-	-	11.0	8.0
	Y120	-	-	-	-	-	-	-

Shapes & Dimensions of Standard Blades Please see page 5

Special Blades (Custom-made blades) Please see page 8

# AIR CUTTERS <HAND-HELD TYPE>

SET A SIDE-EDGED GOING

## HAND-HELD TYPE

**CP** Type  
Standard



**CP-X** Type  
Heavy-duty

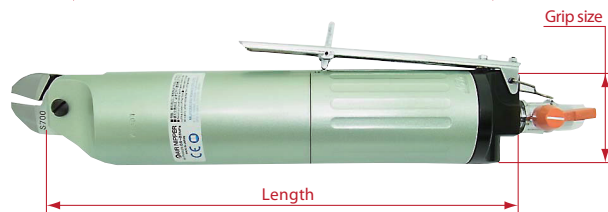

### CP type specification

Model (less blade)	Length (mm)	Weight (g)	Grip size $\phi$ (mm)	Air consumption (cm <sup>3</sup> /stroke)	Power N (approx.)	Air pressure (MPa)
CP10	132	220	36	78	675	0.4~0.5
CP20	170	400	45	227	1,758	0.5~0.6
CP30	201	630	56	438	3,175	0.5~0.6

### CP-X type specification

Model (less blade)	Length (mm)	Weight (g)	Grip size $\phi$ (mm)	Air consumption (cm <sup>3</sup> /stroke)	Power N (approx.)	Air pressure (MPa)
CP20X	257	600	45	389	2,706	0.4~0.5
CP30X	293	940	56	876	5,807	0.5~0.6

### CP type Blade cutting capacity

Model	Blade (*) Carbide tipped	Copper wire	Steel wire	Stainless wire	Piano wire	Plastic	
						Soft	Hard
CP10	S400, CR400, EP400	1.6	1.0	-	-	-	-
	Z400*	1.6	1.0	-	0.5	-	-
	F300, FD300	-	-	-	-	2.6	2.6
	Y400	-	-	-	-	-	-
CP20	S500, P600	2.6	2.0	1.6	-	-	-
	EP600, CR600	2.6	2.0	1.6	-	-	-
	Z600*	2.6	2.0	1.6	1.0	-	-
	F500, FD500	-	-	-	-	6.0	5.0
CP30	Y600	-	-	-	-	-	-
	S700, S900	3.3	2.8	-	-	-	-
	P800, CR800, EP100	3.3	2.8	2.0	-	-	-
	Z800*	3.3	2.8	2.0	1.2	-	-
CP30	F900, FD900	-	-	-	-	8.0	6.5
	Y800	-	-	-	-	-	-

### CP-X type Blade cutting capacity

Model	Blade (*) Carbide tipped	Copper wire	Steel wire	Stainless wire	Piano wire	Plastic	
						Soft	Hard
CP20X	S500, P600	2.6	2.0	1.6	-	-	-
	EP600, CR600	2.6	2.0	1.6	-	-	-
	Z600*	2.6	2.0	1.6	1.0	-	-
	F500, FD500	-	-	-	-	6.0	5.0
CP30X	Y600	-	-	-	-	-	-
	S700, S900	4.5	3.8	-	-	-	-
	P800, CR800, EP100	4.5	3.8	2.6	-	-	-
	Z800*	4.5	3.8	2.6	1.2	-	-
CP30X	F900, FD900	-	-	-	-	8.0	6.5
	Y800	-	-	-	-	-	-

**S, F, Z, P Type**

**FD Type**

**CR Type**

**Y Type**

**EP Type**

Blade	a	b	c	d
S500	35	17	6	12
P600	28	11	5	12
Z600	32	15	5	12
CR600	35	18	6	12
EP600	28	-	5	12
F500	35	15	7	12
FD500	35	14	7	12
Y600	48	-	6	6

(mm)

Blade	a	b	c	d
S700	43	20	7	17
S900	65	38	15	17
P800	37	12	5	17
Z800	38	20	6	17
CR800	43	23	7	17
EP100	34	-	5	17
F900	66	38	10	17
FD900	59	27	10	17
Y800	70	-	9	17

(mm)



nile air tools

# AIR CUTTERS

MACHINE-FITTING TYPE





# AIR CUTTERS (MACHINE-FITTING TYPE)

Optimum for mounting on automatic machine

## MACHINE-FITTING TYPE

### MR-M Type

Standard

### MP-M Type

Heavy-duty

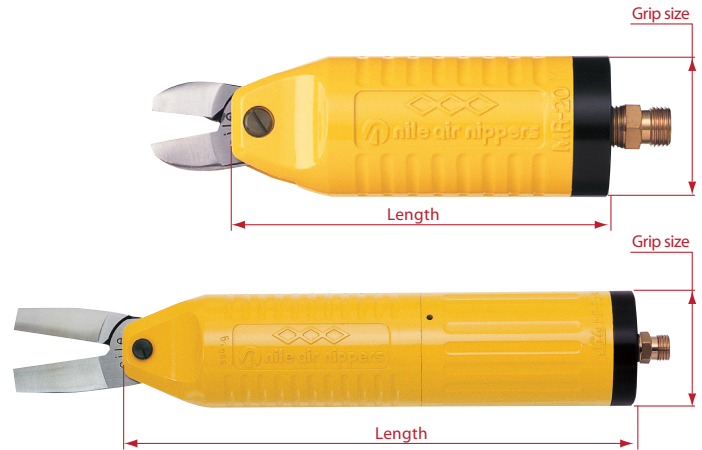

#### MR-M type specification

Model (less blade)	Length (mm)	Weight (g)	Grip size $\phi$ (mm)	Air consumption (cm <sup>3</sup> /stroke)	Power N (approx.)	Air pressure (MPa)
MR3M	101	70	20	31	773	0.4~0.5
MR5M	84	100	30	41	842	0.4~0.5
MR10M	105	160	36	105	1,493	0.4~0.5
MR20M	121	270	45	268	3,490	0.5~0.6
MR30AM	157	470	56	631	5,531	0.5~0.6
MR50FM	173	1,040	75	1,212	3,514	0.5~0.6
MR50AM	215	1,180	75	1,285	12,060	0.5~0.6

#### MP-M type specification

Model (less blade)	Length (mm)	Weight (g)	Grip size $\phi$ (mm)	Air consumption (cm <sup>3</sup> /stroke)	Power N (approx.)	Air pressure (MPa)
MP3M	162	110	20	48	1,090	0.3~0.4
MP5M	134	170	30	68	1,234	0.3~0.4
MP10M	176.5	270	36	171	2,099	0.3~0.4
MP25M	170	450	45	405	2,359	0.5~0.6
MP25AM	208	480	45	459	5,373	0.4~0.5
MP250M	216	510	45	624	6,071	0.5~0.6
MP35AM	249	790	56	1,146	10,118	0.5~0.6
MP55AM	348	2,000	75	2,569	23,026	0.5~0.6

#### MR-M type Blade cutting capacity

Model	Blade (* Carbide tipped)	Copper wire	Steel wire	Stainless wire	Piano wire	Crimping	Plastic	
							Soft	Hard
MR3M	S20, S20S, CR20, EP20	0.8	0.4	-	-	-	-	-
	Z20*, Z20S, ZCR20, ZEP20	0.8	0.4	0.2	0.2	-	-	-
	F10, F10S, FD10, FEP20	-	-	-	-	-	1.0	-
MR5M	S2, S2S, CR2, EP2	1.0	0.5	-	-	-	-	-
	Z2*, Z2S, ZCR2, ZEP2	1.0	0.5	0.3	0.3	-	-	-
	F1, F1S, FD1, FEP2	-	-	-	-	-	2.0	-
MR10M	S4, S4S, CR4, EP4	1.6	1.0	-	-	-	-	-
	Z4*, Z4S, ZCR4, ZEP4	1.6	1.0	0.5	0.5	-	-	-
	F3, F3S, FD3, F3LS, FEP4	-	-	-	-	-	4.0	2.6
MR20M	S5, S5S, P6, CR6, EP6	2.6	2.0	1.6	-	-	-	-
	Z6*, Z6S, ZCR6, ZEP6	2.6	2.0	1.6	1.0	-	-	-
	F5, F5S, FD5, F5LS, FEP6	-	-	-	-	-	7.0	5.0
MR30AM	S7P, S7PS, P8P, CR8P, EP10P, P8PS	3.3	2.8	2.0	-	-	-	-
	Z8P*, Z8PS, ZCR8P, ZEP10P	3.3	2.8	2.0	1.2	-	-	-
	F9P, F9PS, FD9P, FEP10P	-	-	-	-	-	10.0	6.5
MR50FM	F9PF, FD9PF	-	-	-	-	-	12.0	6.5
MR50AM	S120, S120S, P120, CR120, EP120	5.5	4.5	3.5	-	-	-	-
	Z120*, Z120S, ZCR120, ZEP120	5.5	4.5	3.5	1.6	-	-	-
	F120	-	-	-	-	-	11.0	8.0

#### MP-M type Blade cutting capacity

Model	Blade (* Carbide tipped)	Copper wire	Steel wire	Stainless wire	Piano wire	Crimping	Plastic	
							Soft	Hard
MP3M	S20, S20S, CR20, EP20	0.8	0.4	-	-	-	-	-
	Z20*, Z20S, ZCR20, ZEP20	0.8	0.4	0.2	0.2	-	-	-
	F10, F10S, FD10, FEP20	-	-	-	-	-	1.0	-
MP5M	S2, S2S, CR2, EP2	1.0	0.5	-	-	-	-	-
	Z2*, Z2S, ZCR2, ZEP2	1.0	0.5	0.3	0.3	-	-	-
	F1, F1S, FD1, FEP2	-	-	-	-	-	2.0	-
MP10M	S4, S4S, CR4, EP4	1.6	1.0	-	-	-	-	-
	Z4*, Z4S, ZCR4, ZEP4	1.6	1.0	0.5	0.5	-	-	-
	F3, F3S, FD3, F3LS, FEP4	-	-	-	-	-	4.0	2.6
MP25M	S250, S250S, CR250	2.4	1.8	-	-	-	-	-
	F250, F250S, FD250	-	-	-	-	-	8.0	5.0
	S5, S5S, P6, CR6, EP6	2.6	2.0	1.6	-	-	-	-
MP25AM	Z6*, Z6S, ZCR6, ZEP6	2.6	2.0	1.6	1.0	-	-	-
	F5, F5S, FD5, F5LS, FEP6	-	-	-	-	-	7.0	5.0
	S7P1, S7P1S, P8P1, CR8P1, EP10P1	4.0	3.2	2.3	-	-	-	-
MP250M	Z8P1*, ZCR8P1, ZEP10P1	4.0	3.2	2.3	1.2	-	-	-
	F9P1, FD9P1, F9P1S	-	-	-	-	-	8.0	6.5
	S7P, S7PS, P8P, CR8P, EP10P, P8PS	4.8	4.0	2.8	-	-	-	-
MP35AM	Z8P*, Z8PS, ZCR8P, ZEP10P	4.8	4.0	2.8	1.2	-	-	-
	F9P, F9PS, FD9P, FEP10P	-	-	-	-	-	13.0	6.5
	S120, S120S, P120, CR120, EP120	7.0	6.0	4.3	-	-	-	-

Shapes & Dimensions of Standard Blades Please see page 5

Special Blades (Custom-made blades) Please see page 8

# AIR CUTTERS (MACHINE-FITTING TYPE)

No tool is needed for blade replacement.

## MACHINE-FITTING TYPE

### MR-MG Type

Standard

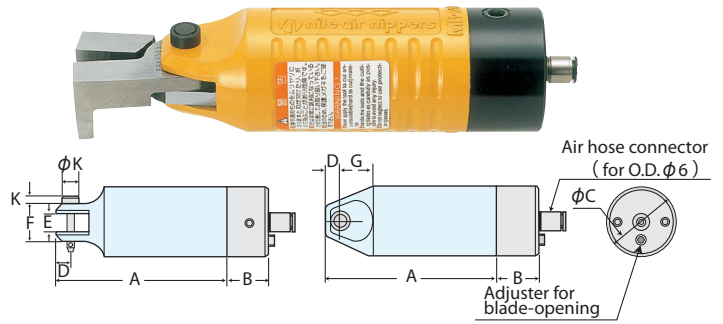

#### MR-MG type specification

Model (less blade)	Weight (g)	Air consumption (cm <sup>3</sup> /stroke)	Power N (approx.)	Air pressure (MPa)	Dimensions (mm)									
					A	B	C	D	E	F	G	H	J	K
MR20MG	338	268	3,490	0.5~0.6	109	27	45	9	12	23	22	-	11	5
MR30AMG	597	631	5,531	0.5~0.6	145	27	56	10	17	30	30	-	12	5

#### MR-MG type Blade cutting capacity

Model	Blade (* Carbide tipped)	Copper wire	Steel wire	Stainless wire	Piano wire	Crimping	Plastic (φmm)	
							Soft	Hard
MR20MG	S5, S5S, P6, CR6, EP6	2.6	2.0	1.6	-	-	-	-
	Z6*, Z6S, ZCR6, ZEP6	2.6	2.0	1.6	1.0	-	-	-
	F5, F5S, FD5, F5LS, FEP6	-	-	-	-	-	7.0	5.0
	Y6, K6	-	-	-	-	-	-	-

Shapes & Dimensions of Standard Blades Please see page 5

Special Blades (Custom-made blades) Please see page 8

#### MR-MG type Blade cutting capacity

Model	Blade (* Carbide tipped)	Copper wire	Steel wire	Stainless wire	Piano wire	Crimping	Plastic (φmm)	
							Soft	Hard
MR30AMG	S7P, S7PS, P8P, CR8P, EP10P, P8PS	3.3	2.8	2.0	-	-	-	-
	Z8P*, Z8PS, ZCR8P, ZEP10P	3.3	2.8	2.0	1.2	-	-	-
	F9P, F9PS, FD9P, FEP10P	-	-	-	-	-	-	10.0 6.5
	Y8P, K8P, Y817P	-	-	-	-	-	-	-
	SH8P	-	-	-	-	-	-	-
	A8P-1.25, A8P-2.0	-	-	-	-	-	1.25/2.0	-
AR8P-1.25, AR8P-2.0	-	-	-	-	-	1.25/2.0	-	

## MACHINE-FITTING TYPE

### MP-MG Type

Heavy-duty



#### MP-MG type specification

Model (less blade)	Weight (g)	Air consumption (cm <sup>3</sup> /stroke)	Power N (approx.)	Air pressure (MPa)	Dimensions (mm)									
					A	B	C	D	E	F	G	H	J	K
MP25AMG	560	459	5,373	0.4~0.5	109	27	45	9	12	23	22	87	11	5
MP35AMG	924	1,146	10,118	0.5~0.6	145	27	56	10	17	30	30	92	12	5

#### MP-MG type Blade cutting capacity

Model	Blade (* Carbide tipped)	Copper wire	Steel wire	Stainless wire	Piano wire	Crimping	Plastic (φmm)	
							Soft	Hard
MP25AMG	S5, S5S, P6, CR6, EP6	2.6	2.0	1.6	-	-	-	-
	Z6*, Z6S, ZCR6, ZEP6	2.6	2.0	1.6	1.0	-	-	-
	F5, F5S, FD5, F5LS, FEP6	-	-	-	-	-	7.0	5.0
	Y6, K6	-	-	-	-	-	-	-

Shapes & Dimensions of Standard Blades Please see page 5

Special Blades (Custom-made blades) Please see page 8

#### MP-MG type Blade cutting capacity

Model	Blade (* Carbide tipped)	Copper wire	Steel wire	Stainless wire	Piano wire	Crimping	Plastic (φmm)	
							Soft	Hard
MP35AMG	S7P, S7PS, P8P, CR8P, EP10P, P8PS	4.8	4.0	2.8	-	-	-	-
	Z8P*, Z8PS, ZCR8P, ZEP10P	4.8	4.0	2.8	1.2	-	-	-
	F9P, F9PS, FD9P, FEP10P	-	-	-	-	-	-	13.0 6.5
	Y8P, K8P, Y817P	-	-	-	-	-	-	-
	SH8P	-	-	-	-	-	-	-
	A8P-1.25, A8P-2.0	-	-	-	-	-	1.25/2.0	-
AR8P-1.25, AR8P-2.0	-	-	-	-	-	1.25/2.0	-	

Blade can be replaced easily and quickly.  
Blade opening-angle can be adjusted.

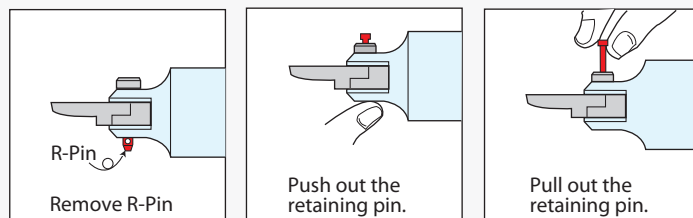

Be sure to secure Retaining Pin with R-Pin attached when Retaining Pin is likely to suffer some drawing-out power or shock. (R-Pin is designed for easy removal.)

# AIR CUTTERS (MACHINE-FITTING TYPE)

SET A SIDE-EDGED GOING

## MACHINE-FITTING TYPE

### CP-M Type

Standard

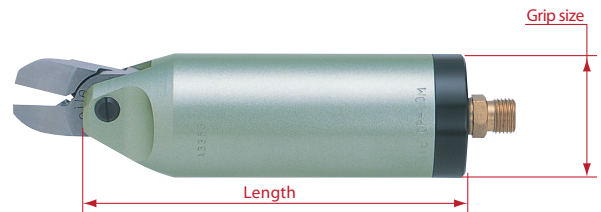

### CP-XM Type

Heavy-duty



#### CP-M type specification

Model (less blade)	Length (mm)	Weight (g)	Grip size $\phi$ (mm)	Air consumption (cm <sup>3</sup> /stroke)	Power N (approx.)	Air pressure (MPa)
CP10M	113	220	36	116	675	0.4~0.5
CP20M	136	400	45	230	1,758	0.5~0.6
CP30M	167	630	56	584	3,175	0.5~0.6

#### CP-XM type specification

Model (less blade)	Length (mm)	Weight (g)	Grip size $\phi$ (mm)	Air consumption (cm <sup>3</sup> /stroke)	Power N (approx.)	Air pressure (MPa)
CP20XM	223	600	45	400	2,706	0.4~0.5
CP30XM	259	940	56	956	5,807	0.5~0.6

#### CP-M type Blade cutting capacity

Model	Blade (*): Carbide tipped	Copper wire	Steel wire	Stainless wire	Piano wire	Plastic	
						Soft	Hard
CP10M	S400, CR400, EP400	1.6	1.0	-	-	-	-
	Z400*	1.6	1.0	-	0.5	-	-
	F300, FD300	-	-	-	-	2.6	2.6
	Y600	-	-	-	-	-	-
CP20M	S500, P600	2.6	2.0	1.6	-	-	-
	EP600, CR600	2.6	2.0	1.6	-	-	-
	Z600*	2.6	2.0	1.6	1.0	-	-
	F500, FD500	-	-	-	-	6.0	5.0
CP30M	Y600	-	-	-	-	-	-
	S700, S900	3.3	2.8	-	-	-	-
	P800, CR800, EP100	3.3	2.8	2.0	-	-	-
	Z800*	3.3	2.8	2.0	1.2	-	-
CP30M	F900, FD900	-	-	-	-	8.0	6.5
	Y800	-	-	-	-	-	-

#### CP-XM type Blade cutting capacity

Model	Blade (*): Carbide tipped	Copper wire	Steel wire	Stainless wire	Piano wire	Plastic	
						Soft	Hard
CP20XM	S500, P600	2.6	2.0	1.6	-	-	-
	EP600, CR600	2.6	2.0	1.6	-	-	-
	Z600*	2.6	2.0	1.6	1.0	-	-
	F500, FD500	-	-	-	-	6.0	5.0
CP30XM	Y600	-	-	-	-	-	-
	S700, S900	4.5	3.8	-	-	-	-
	P800, CR800, EP100	4.5	3.8	2.6	-	-	-
	Z800*	4.5	3.8	2.6	1.2	-	-
CP30XM	F900, FD900	-	-	-	-	8.0	6.5
	Y800	-	-	-	-	-	-

**S, F, Z, P Type**

**FD Type**

**CR Type**

**Y Type**

**EP Type**

Blade	a	b	c	d
S500	35	17	6	12
P600	28	11	5	12
Z600	32	15	5	12
CR600	35	18	6	12
EP600	28	-	5	12
F500	35	15	7	12
FD500	35	14	7	12
Y600	48	-	6	6

(mm)

Blade	a	b	c	d
S700	43	20	7	17
S900	65	38	15	17
P800	37	12	5	17
Z800	38	20	6	17
CR800	43	23	7	17
EP100	34	-	5	17
F900	66	38	10	17
FD900	59	27	10	17
Y800	70	-	9	17

(mm)



nile air tools

# SQUARE AIR CUTTERS

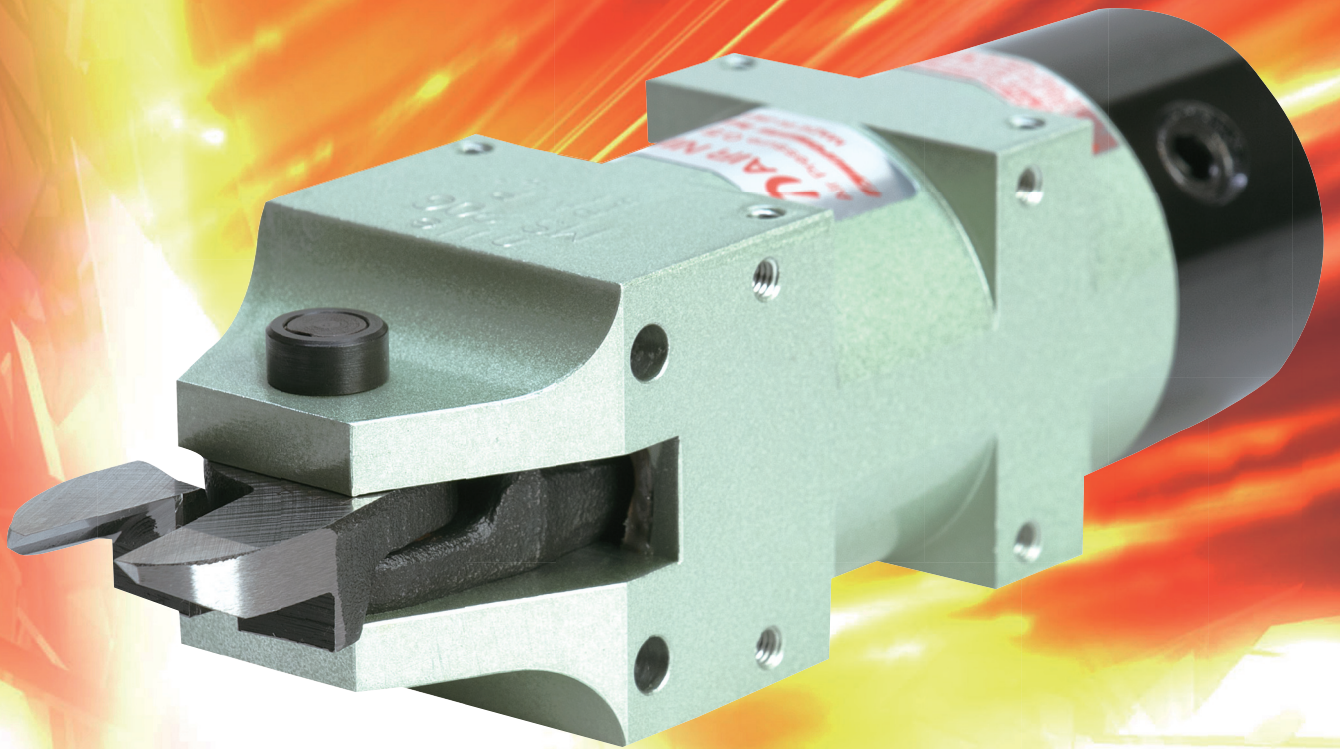

# SQUARE AIR CUTTERS

The square body has many holes for setting bolts to be mounted on any machines or stands.

## MACHINE-FITTING TYPE

### MS Type Standard

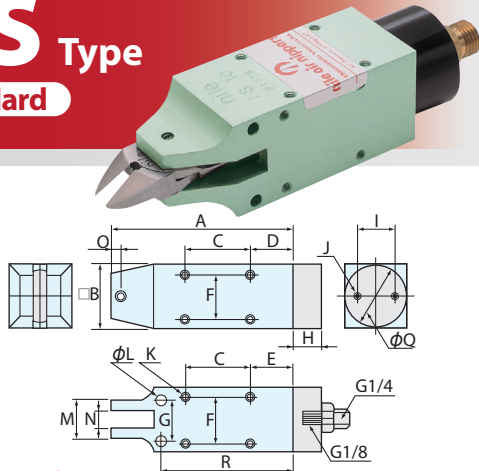

## MACHINE-FITTING TYPE

### MSP Type Heavy-duty

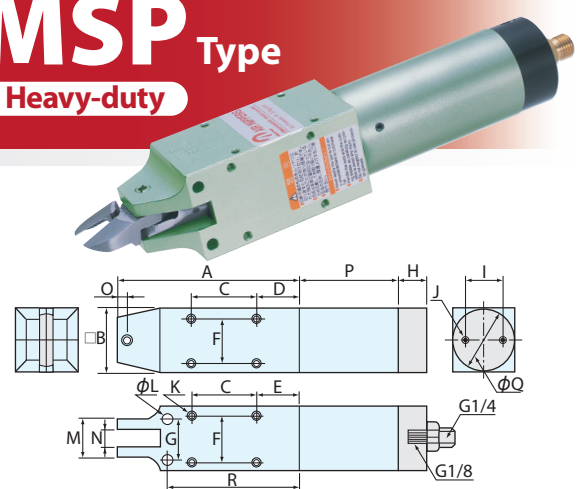

#### MS type specification

Model (less blade)	Weight (g)	Air consumption (cm <sup>3</sup> /stroke)	Power N (approx.)	Air pressure (MPa)	Dimensions (mm)																	
					A	B	C	D	E	F	G	H	I	J	K	L	M	N	O	P	Q	R
<b>MS3</b>	100	31	773	0.4~0.5	89	20	40	19	24	16	14	21	14	M3	M3	3.3	20	7	7	-	19	71
<b>MS5</b>	160	56	842	0.4~0.5	74	30	30	14	19	24	20	20	20	M4	M3	4.3	20	7	7	-	29	55
<b>MS10</b>	260	105	1,493	0.4~0.5	93	36	30	18	23	28	28	20	24	M4	M4	4.3	20	9	7	-	35	65
<b>MS20</b>	430	268	3,490	0.5~0.6	109	45	40	19	24	36	30	20	30	M5	M4	5.3	26	12	9	-	44	81
<b>MS30</b>	810	631	5,531	0.5~0.6	150	56	60	20	30	46	40	20	40	M6	M5	5.3	36	17	15	-	55	110
<b>MS50</b>	1,620	1,285	12,060	0.5~0.6	200	75	80	40	50	62	-	24	-	M8	-	43	25	15	-	-	74.5	-
<b>MS50F</b>	1,680	1,212	3,514	0.5~0.6	150	75	65	20	30	62	-	40	60	M6	M8	-	31	17	14	-	□74	-

#### MSP type specification

Model (less blade)	Weight (g)	Air consumption (cm <sup>3</sup> /stroke)	Power N (approx.)	Air pressure (MPa)	Dimensions (mm)																	
					A	B	C	D	E	F	G	H	I	J	K	L	M	N	O	P	Q	R
<b>MSP3</b>	130	48	1,090	0.3~0.4	89	20	40	19	24	16	14	21	14	M3	M3	3.3	20	7	7	61	19	71
<b>MSP5</b>	220	94	1,234	0.3~0.4	74	30	30	14	19	24	20	20	20	M4	M3	4.3	20	7	7	50	29	55
<b>MSP10</b>	360	174	2,099	0.3~0.4	93	36	30	18	23	28	28	20	24	M4	M4	4.3	20	9	7	71	35	65
<b>MSP20</b>	650	459	5,373	0.4~0.5	109	45	40	19	24	36	30	20	30	M5	M4	5.3	26	12	9	87	44	81
<b>MSP30</b>	1,220	1,146	10,118	0.5~0.6	150	56	60	20	30	46	40	20	40	M6	M5	5.3	36	17	15	92	55	110
<b>MSP50</b>	1,440	2,569	23,026	0.5~0.6	200	75	80	40	50	62	-	24	-	M8	-	43	25	15	133	74.5	-	-

Shapes & Dimensions of Standard Blades [Please see page 5](#) Special Blades (Custom-made blades) [Please see page 8](#)

#### MS type Blade cutting capacity

Model	Blade (* ) Carbide tipped	Copper wire	Steel wire	Stainless wire	Piano wire	Crimping	Plastic	
							Soft	Hard
MS3	S20, S20S, CR20, EP20	0.8	0.4	-	-	-	-	-
	Z20*, Z20S, ZCR20, ZEP20	0.8	0.4	0.2	0.2	-	-	-
	F10, F10S, FD10, FEP20	-	-	-	-	-	1.0	-
MS5	S2, S2S, CR2, EP2	1.0	0.5	-	-	-	-	-
	Z2*, Z2S, ZCR2, ZEP2	1.0	0.5	0.3	0.3	-	-	-
	F1, F1S, FD1, FEP2	-	-	-	-	-	2.0	-
MS10	S4, S4S, CR4, EP4	1.6	1.0	-	-	-	-	-
	Z4*, Z4S, ZCR4, ZEP4	1.6	1.0	0.5	0.5	-	-	-
	F3, F3S, FD3, F3LS, FEP4	-	-	-	-	-	4.0	2.6
	Y4	-	-	-	-	-	-	-
MS20	S5, S5S, CR6, EP6	2.6	2.0	-	-	-	-	-
	Z6*, Z6S, ZCR6, ZEP6	2.6	2.0	1.0	1.0	-	-	-
	F5, F5S, FD5, F5LS, FEP6	-	-	-	-	-	7.0	5.0
MS30	Y6, K6	-	-	-	-	-	-	-
	S7P, S7PS, P8P, CR8P, EP10P, P8PS	3.3	2.8	2.0	-	-	-	-
	Z8P*, Z8PS, ZCR8P, ZEP10P	3.3	2.8	2.0	1.2	-	-	-
	F9P, F9PS, FD9P, FEP10P	-	-	-	-	-	10.0	6.5
	Y8P, K8P, Y817P	-	-	-	-	-	-	-
	SH8P	-	-	-	-	-	-	-
MS50	A8P-1.25, A8P-2.0	-	-	-	-	1.25/2.0	-	-
	AR8P-1.25, AR8P-2.0	-	-	-	-	1.25/2.0	-	-
	S120, S120S, P120, CR120, EP120	5.5	4.5	3.5	-	-	-	-
MS50F	Z120*, Z120S, ZCR120, ZEP120	5.5	4.5	3.5	1.6	-	-	-
	Y120	-	-	-	-	-	-	-
MS50F	F9PF, FD9PF	-	-	-	-	-	12.0	6.5

#### MSP type Blade cutting capacity

Model	Blade (* ) Carbide tipped	Copper wire	Steel wire	Stainless wire	Piano wire	Crimping	Plastic	
							Soft	Hard
MSP3	S20, S20S, CR20, EP20	0.8	0.4	-	-	-	-	-
	Z20*, Z20S, ZCR20, ZEP20	0.8	0.4	0.2	0.2	-	-	-
	F10, F10S, FD10, FEP20	-	-	-	-	-	1.0	-
MSP5	S2, S2S, CR2, EP2	1.0	0.5	-	-	-	-	-
	Z2*, Z2S, ZCR2, ZEP2	1.0	0.5	0.3	0.3	-	-	-
	F1, F1S, FD1, FEP2	-	-	-	-	-	2.0	-
MSP10	S4, S4S, CR4, EP4	1.6	1.0	-	-	-	-	-
	Z4*, Z4S, ZCR4, ZEP4	1.6	1.0	0.5	0.5	-	-	-
	F3, F3S, FD3, F3LS, FEP4	-	-	-	-	-	4.0	2.6
	Y4	-	-	-	-	-	-	-
MSP20	S5, S5S, CR6, EP6	2.6	2.0	-	-	-	-	-
	Z6*, Z6S, ZCR6, ZEP6	2.6	2.0	1.0	1.0	-	-	-
	F5, F5S, FD5, F5LS, FEP6	-	-	-	-	-	7.0	5.0
MSP30	Y6, K6	-	-	-	-	-	-	-
	S7P, S7PS, P8P, CR8P, EP10P, P8PS	4.8	4.0	-	-	-	-	-
	Z8P*, Z8PS, ZCR8P, ZEP10P	4.8	4.0	-	1.2	-	-	-
	F9P, F9PS, FD9P, FEP10P	-	-	-	-	-	13.0	6.5
	Y8P, K8P, Y817P	-	-	-	-	-	-	-
	SH8P	-	-	-	-	-	-	-
MSP50	A8P-1.25/2.0/5.5, A8WP-1.25-2.0/2.0-5.5	-	-	-	-	-	1.25/20/55	-
	AR8P-1.25/2.0/5.5, AR8WP-1.25-2.0/2.0-5.5	-	-	-	-	-	1.25/20/55	-
	S120, S120S, P120, CR120, EP120	7.0	6.0	4.3	-	-	-	-
MSP50F	Z120*, Z120S, ZCR120, ZEP120	7.0	6.0	4.3	2.0	-	-	-
	F120	-	-	-	-	-	-	11.0 8.0
MSP50F	Y120	-	-	-	-	-	-	-

# SQUARE AIR CUTTERS

The square main body has numerous holes for setting bolts.  
No tool is needed for blade replacement.

## MACHINE-FITTING TYPE

### MS-G Type

Standard

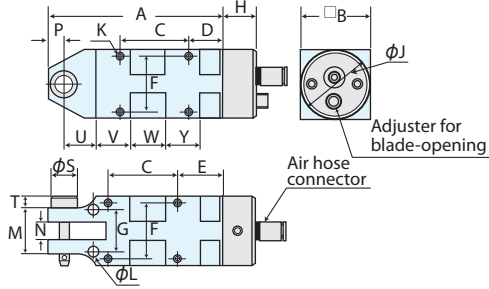
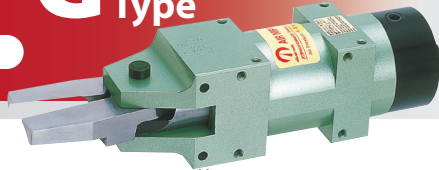

## MACHINE-FITTING TYPE

### MSP-G

Heavy-duty

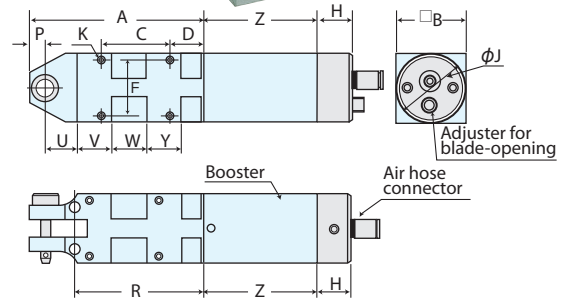

#### MS-G type specification

Model (less blade)	Weight (g)	Air consumption (cm <sup>3</sup> /stroke)	Power N (approx.)	Air pressure (MPa)	Dimensions (mm)																					
					A	B	C	D	E	F	G	H	J	K	L	M	N	P	R	S	T	U	V	W	Y	Z
MS3G	75	31	773	0.4~0.5	89	20	40	19	24	16	14	12	20	M3	3.3	20	7	7	71	11	5	3	25	25	15	-
MS5G	141	56	842	0.4~0.5	74	30	30	14	19	24	18	15	30	M3	4.3	20	7	7	54	11	5	13	15	15	15	-
MS10G	254	105	1,493	0.4~0.5	93	36	30	18	23	28	28	24	36	M4	4.3	23	9	7	65	11	5	16	27	15	15	-
MS10AG	248	122	1,879	0.5~0.6	93	36	30	18	23	28	28	24	36	M4	4.3	26	12	7	65	11	5	16	27	15	15	-
MS20G	425	268	3,490	0.5~0.6	109	45	40	19	24	36	30	27	45	M4	5.3	26	12	9	81	11	5	15	31	25	15	-
MS30G	788	631	5,531	0.5~0.6	150	56	60	20	30	46	40	27	56	M5	5.3	36	17	15	110	12	5	20	41	38	22	-

#### MSP-G type specification

Model (less blade)	Weight (g)	Air consumption (cm <sup>3</sup> /stroke)	Power N (approx.)	Air pressure (MPa)	Dimensions (mm)																					
					A	B	C	D	E	F	G	H	J	K	L	M	N	P	R	S	T	U	V	W	Y	Z
MSP3G	111	48	1,090	0.3~0.4	89	20	40	19	24	16	14	12	20	M3	3.3	20	7	7	71	11	5	3	25	25	15	61
MSP5G	205	94	1,234	0.3~0.4	74	30	30	14	19	24	18	15	30	M3	4.3	20	7	7	54	11	5	13	15	15	15	50
MSP10G	369	174	2,099	0.3~0.4	93	36	30	18	23	28	28	24	36	M4	4.3	23	9	7	65	11	5	16	27	15	15	71.5
MSP10AG	366	209	2,750	0.4~0.5	93	36	30	18	23	28	28	24	36	M4	4.3	26	12	7	65	11	5	16	27	15	15	71.5
MSP20G	648	373	5,373	0.4~0.5	109	45	40	19	24	36	30	27	45	M4	5.3	26	12	9	81	11	5	15	31	25	15	87
MSP30G	1,115	1,146	10,118	0.5~0.6	150	56	60	20	30	46	40	27	56	M5	5.3	36	17	15	110	12	5	20	41	38	22	92

Shapes & Dimensions of Standard Blades Please see page 5 Special Blades (Custom-made blades) Please see page 8

#### MS-G type Blade cutting capacity

Model	Blade (* Carbide tipped)	Copper wire	Steel wire	Stainless wire	Piano wire	Crimping	Plastic	
							Soft	Hard
MS3G	S20, S20S, CR20, EP20	0.8	0.4	-	-	-	-	-
	Z20*, Z20S, ZCR20, ZEP20	0.8	0.4	0.2	0.2	-	-	-
	F10, F10S, FD10, FEP20	-	-	-	-	-	1.0	-
MS5G	S2, S2S, CR2, EP2	1.0	0.5	-	-	-	-	-
	Z2*, Z2S, ZCR2, ZEP2	1.0	0.5	0.3	0.3	-	-	-
	F1, F1S, FD1, FEP2	-	-	-	-	-	2.0	-
MS10G	S4, S4S, CR4, EP4	1.6	1.0	-	-	-	-	-
	Z4*, Z4S, ZCR4, ZEP4	1.6	1.0	0.5	0.5	-	-	-
	F3, F3S, FD3, F3LS, FEP4	-	-	-	-	-	4.0	2.6
	Y4	-	-	-	-	-	-	-
MS10AG	S5A, S5AS, CR6A, EP6A	1.8	1.2	1.0	-	-	-	-
	Z6A*, ZCR6A, ZEP6A	1.8	1.2	1.0	0.5	-	-	-
	F5A, F5AS, FD5A, FEP6A	-	-	-	-	-	4.0	2.6
MS20G	S5, S5S, P6, CR6, EP6	2.6	2.0	1.6	-	-	-	-
	Z6*, Z6S, ZCR6, ZEP6	2.6	2.0	1.6	1.0	-	-	-
	F5, F5S, FD5, F5LS, FEP6	-	-	-	-	-	7.0	5.0
MS30G	S7P, S7PS, P8P, CR8P, EP10P, P8PS	3.3	2.8	2.0	-	-	-	-
	Z8P*, Z8PS, ZCR8P, ZEP10P	3.3	2.8	2.0	1.2	-	-	-
	F9P, F9PS, FD9P, FEP10P	-	-	-	-	-	10.0	6.5
	Y8P, K8P, Y817P	-	-	-	-	-	-	-
	SH8P	-	-	-	-	-	-	-
A8P-1.25, A8P-2.0	-	-	-	-	-	1.25/2.0	-	
AR8P-1.25, AR8P-2.0	-	-	-	-	-	1.25/2.0	-	

#### MSP-G type Blade cutting capacity

Model	Blade (* Carbide tipped)	Copper wire	Steel wire	Stainless wire	Piano wire	Crimping	Plastic	
							Soft	Hard
MSP3G	S20, S20S, CR20, EP20	0.8	0.4	-	-	-	-	-
	Z20*, Z20S, ZCR20, ZEP20	0.8	0.4	0.2	0.2	-	-	-
	F10, F10S, FD10, FEP20	-	-	-	-	-	1.0	-
MSP5G	S2, S2S, CR2, EP2	1.0	0.5	-	-	-	-	-
	Z2*, Z2S, ZCR2, ZEP2	1.0	0.5	0.3	0.3	-	-	-
	F1, F1S, FD1, FEP2	-	-	-	-	-	2.0	-
MSP10G	S4, S4S, CR4, EP4	1.6	1.0	-	-	-	-	-
	Z4*, Z4S, ZCR4, ZEP4	1.6	1.0	0.5	0.5	-	-	-
	F3, F3S, FD3, F3LS, FEP4	-	-	-	-	-	4.0	2.6
	Y4	-	-	-	-	-	-	-
MSP10AG	S5A, S5AS, CR6A, EP6A	1.8	1.2	1.0	-	-	-	-
	Z6A*, ZCR6A, ZEP6A	1.8	1.2	1.0	0.5	-	-	-
	F5A, F5AS, FD5A, FEP6A	-	-	-	-	-	4.0	2.6
MSP20G	S5, S5S, P6, CR6, EP6	2.6	2.0	1.6	-	-	-	-
	Z6*, Z6S, ZCR6, ZEP6	2.6	2.0	1.6	1.0	-	-	-
	F5, F5S, FD5, F5LS, FEP6	-	-	-	-	-	7.0	5.0
MSP30G	S7P, S7PS, P8P, CR8P, EP10P, P8PS	3.3	2.8	2.0	-	-	-	-
	Z8P*, Z8PS, ZCR8P, ZEP10P	3.3	2.8	2.0	1.2	-	-	-
	F9P, F9PS, FD9P, FEP10P	-	-	-	-	-	10.0	6.5
	Y8P, K8P, Y817P	-	-	-	-	-	-	-
	SH8P	-	-	-	-	-	-	-
A8P-1.25/2.0/5.5, A8WP-1.25-2.0/2.0-5.5	-	-	-	-	-	1.25/20/5.5	-	
AR8P-1.25/2.0/5.5, AR8WP-1.25-2.0/2.0-5.5	-	-	-	-	-	1.25/20/5.5	-	

# SQUARE AIR CUTTERS

## MACHINE-FITTING TYPE

### WS Type

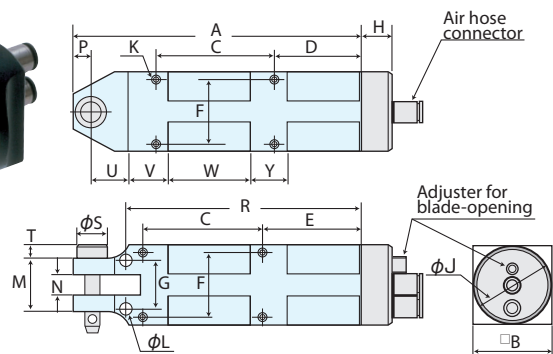
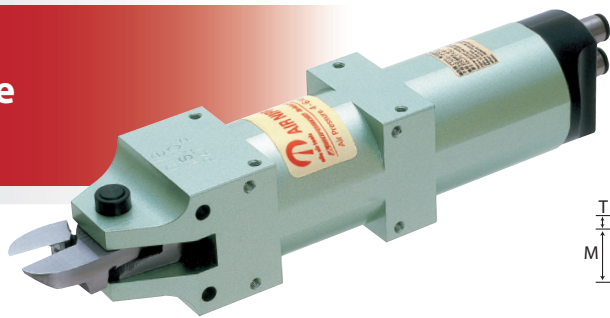

#### WS type specification

Model (less blade)	Weight (g)	Air consumption (cm <sup>3</sup> /stroke)	Power N (approx.)	Air pressure (MPa)	Dimensions (mm)																				
					A	B	C	D	E	F	G	H	J	K	L	M	N	P	R	S	T	U	V	W	Y
<b>WS3</b>	88	41	494	0.4~0.5	107	20	43	34	39	16	14	6	20	M3	3.3	20	7	7	89	11	5	3	24	30	13
<b>WS5</b>	179	71	800	0.4~0.5	104	30	43	31	36	24	18	11	30	M3	4.3	20	7	7	84	11	5	13	14	30	13
<b>WS10</b>	309	179	1,420	0.4~0.5	142	36	55	42	47	28	28	18	36	M4	4.3	23	9	7	114	11	5	16	27	40	15
<b>WS20</b>	537	516	3,115	0.5~0.6	170	45	55	65	70	36	30	18	45	M4	5.3	26	12	9	142	11	5	15	31	40	20

#### WS type Blade cutting capacity

Model	Blade	Copper wire	Steel wire	Plastic
WS3	FW10, FW10S	-	-	1.0
	SW20, SW20S	0.8	0.4	-
WS5	FW1, FW1S	-	-	2.0
	SW2, SW2S	1.0	0.5	-
WS10	FW3, FW3S	-	-	4.0
	SW4, SW4S	1.6	1.0	-
WS20	FW5, FW5S	-	-	7.0
	SW5, SW5S	2.6	2.0	-

Blade	a	b	c
FW10	24	12	2.5~3.0
FW10S	24	12	2.5~3.0
FW1	24	12	3.0~3.5
FW1S	24	12	3.0~3.5
FW3	27	13	5.0~5.5
FW3S	27	13	5.0~5.5
FW5	35	17	8.0~8.5
FW5S	35	17	8.0~8.5
SW20	24	10	2.5~3.0
SW20S	24	12	2.5~3.0
SW2	24	10	3.0~3.5
SW2S	24	12	3.0~3.5
SW4	27	13	5.0~5.5
SW4S	27	13	5.0~5.5
SW5	35	20	8.0~8.5
SW5S	35	17	8.0~8.5

## MACHINE-FITTING TYPE

### MSK Type

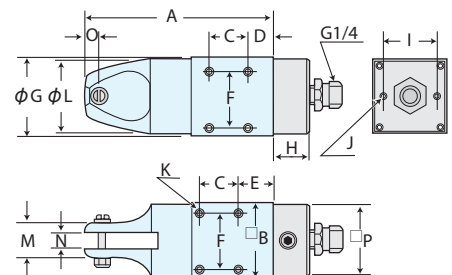
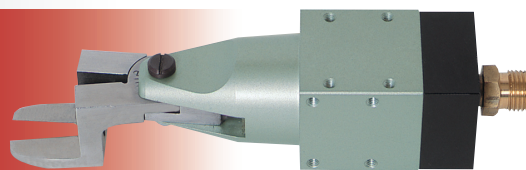

#### MSK type specification

Model (less blade)	Weight (g)	Air consumption (cm <sup>3</sup> /stroke)	Power N (approx.)	Air pressure (MPa)	Dimensions (mm)															
					A	B	C	D	E	F	G	H	I	J	K	L	M	N	O	P
<b>MSK10</b>	190	105	1,493	0.4~0.5	87	36	18	10	15	28	35	17	24	M4	M4	33	18	9	7	35
<b>MSK20</b>	340	270	3,490	0.5~0.6	102	45	20	15	20	36	44	17	30	M5	M4	42	24	12	9	44
<b>MSK30</b>	590	631	5,531	0.5~0.6	141	56	27	18	26	46	55	17	40	M6	M5	54	34	17	15	55

Shapes & Dimensions of Standard Blades Please see page 5 Special Blades (Custom-made blades) Please see page 8

#### MSK type Blade cutting capacity

Model	Blade (* Carbide tipped)	Copper wire	Steel wire	Stainless wire	Piano wire	Crimping	Plastic Soft Hard
MSK10	S4, S4S, CR4, EP4	1.6	1.0	-	-	-	-
	Z4*, Z4S, ZCR4, ZEP4	1.6	1.0	0.5	0.5	-	-
	F3, F3S, FD3, F3LS, FEP4	-	-	-	-	-	4.0 2.6
	Y4	-	-	-	-	-	-
MSK20	S5, S5S, P6, CR6, EP6	2.6	2.0	1.6	-	-	-
	Z6*, Z6S, ZCR6, ZEP6	2.6	2.0	1.6	1.0	-	-
	F5, F5S, FD5, F5LS, FEP6	-	-	-	-	-	7.0 5.0
	Y6, K6	-	-	-	-	-	-

#### MSK type Blade cutting capacity

Model	Blade (* Carbide tipped)	Copper wire	Steel wire	Stainless wire	Piano wire	Crimping	Plastic Soft Hard
MSK10	S7P, S7PS, P8P, CR8P, EP10P, P8PS	3.3	2.8	2.0	-	-	-
	Z8P*, Z8PS, ZCR8P, ZEP10P	3.3	2.8	2.0	1.2	-	-
	F9P, F9PS, FD9P, FEP10P	-	-	-	-	-	10.0 6.5
MSK30	Y8P, K8P, Y817P	-	-	-	-	-	-
	SH8P	-	-	-	-	-	-
	A8P-1.25, A8P-2.0	-	-	-	-	1.25/2.0	-
	AR8P-1.25, AR8P-2.0	-	-	-	-	1.25/2.0	-

# SQUARE AIR CUTTERS

## MACHINE-FITTING TYPE

### MS-V Type

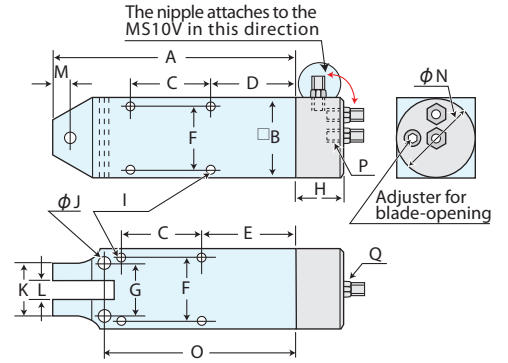
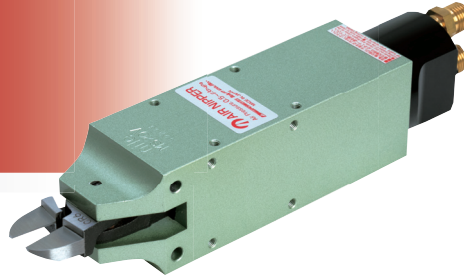

#### MS-V type specification

Model (less blade)	Weight (g)	Air consumption (cm <sup>3</sup> /stroke)	Power N (approx.)	Air pressure (MPa)	Dimensions (mm)																
					A	B	C	D	E	F	G	H	I	J	K	L	M	N	O	P	Q
<b>MS10V</b>	345	107	1,387	0.4~0.5	116	36	30	41	46	28	28	23	M4	4.3	20	9	7	36	88	G1/8	nipple R1/8×G1/4
<b>MS20V</b>	650	340	3,335	0.5~0.6	147	45	40	57	62	36	30	31	M4	5.3	26	12	9	45	119	G1/8	nipple R1/8×G1/4
<b>MS30V</b>	1,150	569	5,376	0.5~0.6	185	56	60	55	65	46	40	33	M5	5.3	36	17	15	56	145	G1/8	nipple R1/8×G1/4

#### MS-V type Blade cutting capacity

Model	Blade (* Carbide tipped)	Copper wire	Steel wire	Stainless wire	Piano wire	Crimping	Plastic	
							Soft	Hard
MS10V	S4, S4S, CR4, EP4	1.6	1.0	-	-	-	-	-
	Z4*, Z4S, ZCR4, ZEP4	1.6	1.0	0.5	0.5	-	-	-
	F3, F3S, FD3, F3LS, FEP4	-	-	-	-	-	4.0	2.6
	Y4	-	-	-	-	-	-	-
MS20V	S5, S5S, P6, CR6, EP6	2.6	2.0	1.6	-	-	-	-
	Z6*, Z6S, ZCR6, ZEP6	2.6	2.0	1.6	1.0	-	-	-
	F5, F5S, FD5, F5LS, FEP6	-	-	-	-	-	7.0	5.0
	Y6, K6	-	-	-	-	-	-	-

#### MS-V type Blade cutting capacity

Model	Blade (* Carbide tipped)	Copper wire	Steel wire	Stainless wire	Piano wire	Crimping	Plastic	
							Soft	Hard
MS10V	S7P, S7PS, P8P, CR8P, EP10P, P8PS	3.3	2.8	2.0	-	-	-	-
	Z8P*, Z8PS, ZCR8P, ZEP10P	3.3	2.8	2.0	1.2	-	-	-
	F9P, F9PS, FD9P, FEP10P	-	-	-	-	-	10.0	6.5
	Y8P, K8P, Y817P	-	-	-	-	-	-	-
MS20V	SH8P	-	-	-	-	-	-	-
	A8P-1.25, A8P-2.0	-	-	-	-	-	1.25/2.0	-
	AR8P-1.25, AR8P-2.0	-	-	-	-	-	1.25/2.0	-

Shapes & Dimensions of Standard Blades Please see page 5

Special Blades (Custom-made blades) Please see page 8

## MACHINE-FITTING TYPE

### MSB Type

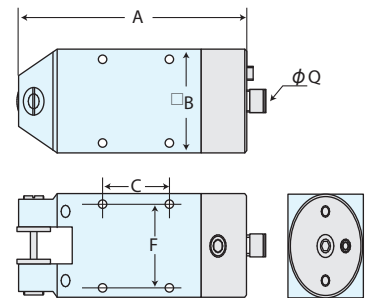
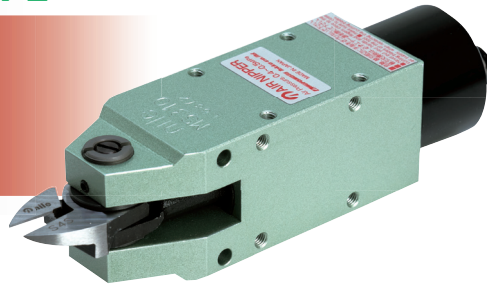

#### MSB type specification

Model (less blade)	Weight (g)	Air consumption (cm <sup>3</sup> /stroke)	Power N (approx.)	Air pressure (MPa)	Dimensions (mm)				
					A	B	C	F	Q
<b>MSB10</b>	271	105	1,493	0.4~0.5	117	36	30	28	6
<b>MSB20</b>	487	268	3,490	0.5~0.6	136	45	40	30	6
<b>MSB30</b>	925	631	5,531	0.5~0.6	177	56	60	40	6

Shapes & Dimensions of Standard Blades Please see page 5

Special Blades (Custom-made blades) Please see page 8

#### MSB type Blade cutting capacity

Model	Blade (* Carbide tipped)	Copper wire	Steel wire	Stainless wire	Piano wire	Crimping	Plastic	
							Soft	Hard
MSB10	S4, S4S, CR4, EP4	1.6	1.0	-	-	-	-	-
	Z4*, Z4S, ZCR4, ZEP4	1.6	1.0	0.5	0.5	-	-	-
	F3, F3S, FD3, F3LS, FEP4	-	-	-	-	-	4.0	2.6
	Y4	-	-	-	-	-	-	-
MSB20	S5, S5S, P6, CR6, EP6	2.6	2.0	1.6	-	-	-	-
	Z6*, Z6S, ZCR6, ZEP6	2.6	2.0	1.6	1.0	-	-	-
	F5, F5S, FD5, F5LS, FEP6	-	-	-	-	-	7.0	5.0
	Y6, K6	-	-	-	-	-	-	-

#### MSB type Blade cutting capacity

Model	Blade (* Carbide tipped)	Copper wire	Steel wire	Stainless wire	Piano wire	Crimping	Plastic	
							Soft	Hard
MSB10	S7P, S7PS, P8P, CR8P, EP10P, P8PS	3.3	2.8	2.0	-	-	-	-
	Z8P*, Z8PS, ZCR8P, ZEP10P	3.3	2.8	2.0	1.2	-	-	-
	F9P, F9PS, FD9P, FEP10P	-	-	-	-	-	10.0	6.5
	Y8P, K8P, Y817P	-	-	-	-	-	-	-
MSB20	SH8P	-	-	-	-	-	-	-
	A8P-1.25, A8P-2.0	-	-	-	-	-	1.25/2.0	-
	AR8P-1.25, AR8P-2.0	-	-	-	-	-	1.25/2.0	-





nile air tools

# VERTICAL TYPE AIR CUTTERS SLIDING AIR CUTTERS



MF10

## VERTICAL TYPE

# MF Type

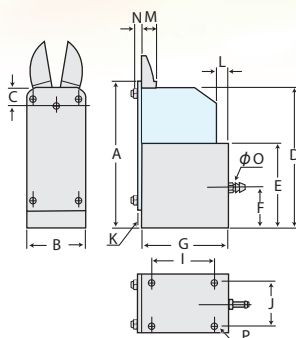

### MF type specification

Model (less blade)	Weight (g)	Air consumption (cm <sup>3</sup> /stroke)	Air pressure (MPa)	Blade	Plastic (Φmm)	Dimensions (mm)														
						A	B	C	D	E	F	G	I	J	K	L	M	N	O	P
<b>MF3</b>	71	12	0.4~0.5	F10E,F10EK	1.0	71	20	8	68	40	10	38	25	14	2	10	7	3.3	4	M4/D10
<b>MF5</b>	73	28	0.4~0.5	F1E,F1EK	1.2	73	29	9	69	41	20	44	30	22	2	7	7	4.0	4	M4/D10
<b>MF10</b>	96	65	0.4~0.5	F3E,F3EK	2.5	96	35	10	91	56	20	53	40	26	2	8	9	4.0	4	M4/D15
<b>MF20</b>	110	122	0.5~0.6	F5E,F5EK	4.5	110	44	13	102	60	20	64	45	34	2	13	12	3.0	4	M4/D15

Blade	(mm)			
	a	b	c	d
F10E, F10EK	24	13	3.5	7
F1E, F1EK	24	12	5.5	7
F3E, F3EK	27	13	7	9
F5E, F5EK	35	18	9	12

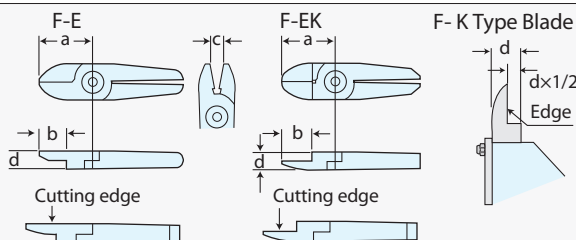

# SLIDING AIR CUTTERS

## MACHINE-FITTING TYPE

### CF Type

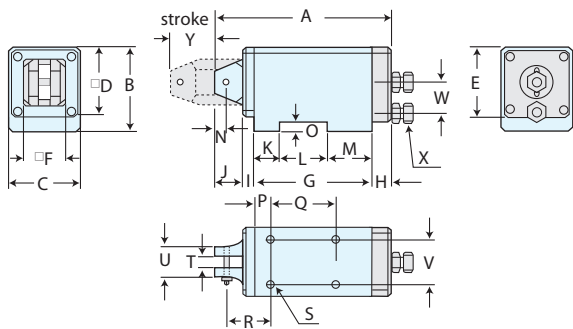
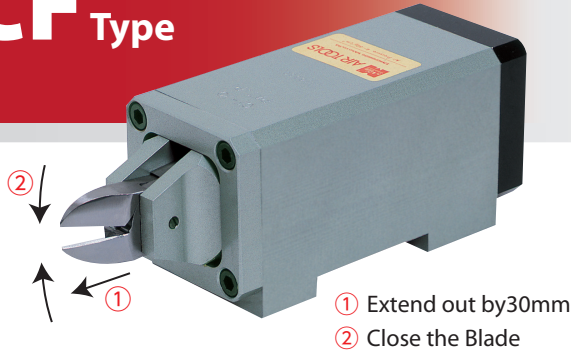

#### CF type specification

Model (less blade)	Weight (g)	Air consumption (cm <sup>3</sup> /stroke)	Air pressure (MPa)	Dimensions (mm)																								
				A	B	C	D	E	F	G	H	I	J	K	L	M	N	O	P	Q	R	S	T	U	V	W	X	Y
CF5	570	265	0.4~0.5	124	54	44	44	47	28	80	15	10	19	16	33	31	7	8	10	45	32	M6	7	20	30	18	G1/4	30
CF10	940	436	0.4~0.5	146	64	54	54	54	34	100	15	10	21	26	40	34	7	8	16	60	40	M6	9	20	30	19	G1/4	30
CF20	1,300	792	0.5~0.6	165	70	62	62	62	42	117	15	10	23	26	55	36	9	8	16	75	40	M6	12	26	34	21	G1/4	30

#### CL type specification

Model (less blade)	Weight (g)	Air consumption (cm <sup>3</sup> /stroke)	Air pressure (MPa)	Dimensions (mm)																								
				A	B	C	D	E	F	G	H	I	J	K	L	M	N	O	P	Q	R	S	T	U	V	W	X	Y
CL5	650	137	0.4~0.5	165	60	44	59	59	30	73	35	7	50	18	37	18	7	8	9	55	59	M6	7	20	30	23	G1/4	30
CL10	1,050	253	0.4~0.5	187	70	54	70	70	36	88	35	7	57	23	40	25	7	8.5	15	58	72	M6	9	20	34	28.5	G1/4	30
CL20	1,450	501	0.5~0.6	205	80	62	80	80	42	104	30	8	63	28	50	26	9	10	18	70	80	M6	12	26	40	32.5	G1/4	30

Shapes & Dimensions of Standard Blades Please see page 5 Special Blades (Custom-made blades) Please see page 8

#### CF type Blade cutting capacity

Model	Blade (* Carbide tipped)	Copper wire	Steel wire	Stainless wire	Piano wire	Crimping	Plastic (φmm)	
							Soft	Hard
CF5	S2, S2S, CR2, EP2	1.0	0.5	-	-	-	-	-
	* Z2S, ZCR2, ZEP2	1.0	0.5	0.3	0.3	-	-	-
	F1, F1S, FD1, FEP2	-	-	-	-	-	2.0	-
CF10	S4, S4S, CR4, EP4	1.6	1.0	-	-	-	-	-
	Z4*, Z4S, ZCR4, ZEP4	1.6	1.0	0.5	0.5	-	-	-
	F3, F3S, FD3, F3LS, FEP4	-	-	-	-	-	4.0	2.6
	Y4	-	-	-	-	-	-	-
CF20	S5, S5S, P6, CR6, EP6	2.6	2.0	1.6	-	-	-	-
	Z6*, Z6S, ZCR6, ZEP6	2.6	2.0	1.6	1.0	-	-	-
	F5, F5S, FD5, F5LS, FEP6	-	-	-	-	-	7.0	5.0
	Y6, K6	-	-	-	-	-	-	-

#### CL type Blade cutting capacity

Model	Blade (* Carbide tipped)	Copper wire	Steel wire	Stainless wire	Piano wire	Crimping	Plastic (φmm)	
							Soft	Hard
CL5	S2, S2S, CR2, EP2	1.0	0.5	-	-	-	-	-
	Z2*, Z2S, ZCR2, ZEP2	1.0	0.5	0.3	0.3	-	-	-
	F1, F1S, FD1, FEP2	-	-	-	-	-	2.0	-
CL10	S4, S4S, CR4, EP4	1.6	1.0	-	-	-	-	-
	Z4*, Z4S, ZCR4, ZEP4	1.6	1.0	0.5	0.5	-	-	-
	F3, F3S, FD3, F3LS, FEP4	-	-	-	-	-	4.0	2.6
	Y4	-	-	-	-	-	-	-
CL20	S5, S5S, P6, CR6, EP6	2.6	2.0	1.6	-	-	-	-
	Z6*, Z6S, ZCR6, ZEP6	2.6	2.0	1.6	1.0	-	-	-
	F5, F5S, FD5, F5LS, FEP6	-	-	-	-	-	7.0	5.0
	Y6, K6	-	-	-	-	-	-	-

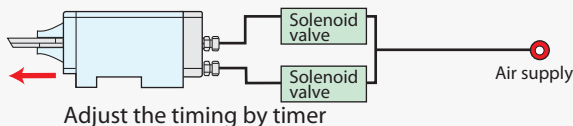
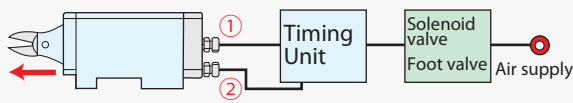

- Use Three-way valve for solenoid valve and foot valve
- Adjust the timing of 1 and 2 by timing unit or timer
- Slide part body can rotate by 90



nile air tools

# SN TYPE SLIDING AIR CUTTERS



# SN TYPE SLIDING AIR CUTTERS

SN-series : Pull&Cut type    SNP-series : Push&Cut type

## MACHINE-FITTING TYPE

### SN Type Pull&Cut type

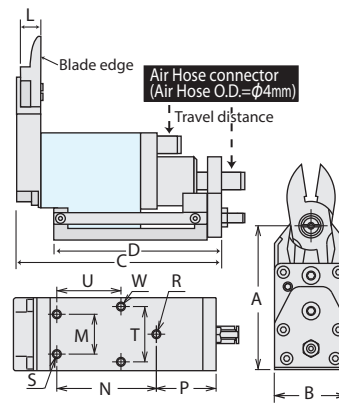

### SN type specification

Model (less blade)	Weight (g)	Air consumption (cm <sup>3</sup> /stroke)	Power N (approx.)	Air pressure (MPa)	Dimensions (mm)											
					A	B	C	D	M	N	P	R	S	T	U	W
SN1	140	16	312	0.5	61	16.5	80	65	-	30	20	M4	-	-	-	-
SN2	160	21	429	0.5	61	19	80	65	-	30	20	M4	-	-	-	-
SN3	170	24	613	0.5	59	23	79.6	65	12	37	25	M4	M4D5	15	23	M4
SN5	220	47	1,013	0.5	63	28	83.6	69	14	40	26	M4	M4D6	20	24	M4
SN10	300	60	1,254	0.5	70	33	91.6	75	18	45	27	M4	M4D6	25	29	M4
SN20	595	153	1,671	0.5	82	42	110	90	22	58	28	M4	M4D7	30	32	M5

## MACHINE-FITTING TYPE

### SNP Type Push&Cut type

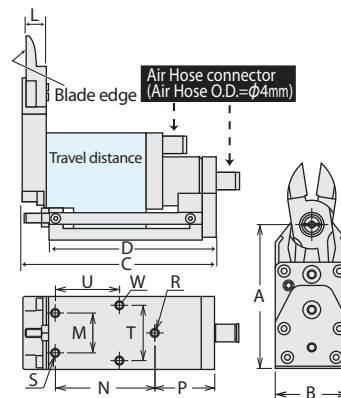
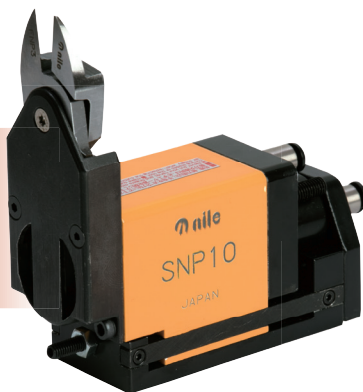

### SNP type specification

Model (less blade)	Weight (g)	Air consumption (cm <sup>3</sup> /stroke)	Power N (approx.)	Air pressure (MPa)	Dimensions (mm)											
					A	B	C	D	M	N	P	R	S	T	U	W
SNP1	140	16	312	0.5	61	16.5	75	65	-	30	20	M4	-	-	-	-
SNP2	160	21	429	0.5	61	19	75	65	-	30	20	M4	-	-	-	-
SNP3	170	24	613	0.5	59	23	74.6	65	12	37	25	M4	M4D5	15	23	M4
SNP5	220	47	1,013	0.5	63	28	78.6	69	14	40	26	M4	M4D6	20	24	M4
SNP10	300	60	1,254	0.5	70	33	86.6	75	18	45	27	M4	M4D6	25	29	M4
SNP20	595	153	1,671	0.5	82	42	105	90	22	58	28	M4	M4D7	30	32	M5

## REMARKABLE FEATURES

### Point 1

"Pull & Cut"(SN-series) and "Push & Cut"(SNP-series) are lined up for your choice. The unit travel distance is freely adjustable within 0-5mm.

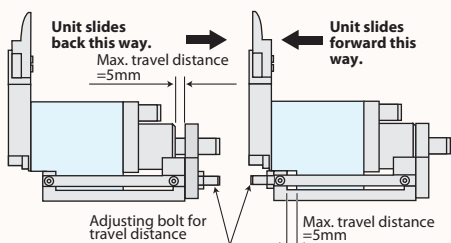

### Point 3

Any special cutting blade can be designed and manufactured to meet your application even for 1 piece.

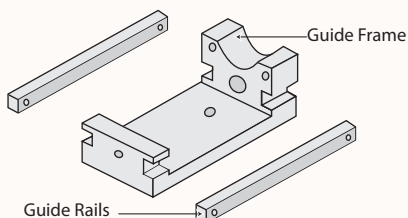

### Point 2

The blade opening is adjustable by turning the adjusting bolt.

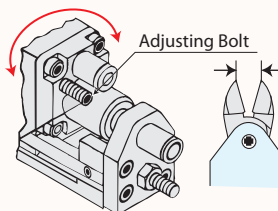

Model	Blade	Model	Blade	(mm)	
				Min.	Max.
SN2	FN10	SNP2	FNP10	1.0	2.8
SN3	FN10	SNP3	FNP10	1.5	3.5
SN5	FN1	SNP5	FNP1	2.0	5.5
SN10	FN3	SNP10	FNP3	3.0	7.0
SN20	FN5	SNP20	FNP5	5.0	8.5

### Point 4

Cutting units are guided with parallel rails while traveling assuring the minimum play in vertical and horizontal direction.

### Point 5

Blade Holder can be set on the stand base at 90° angle either to left or right as illustrated. (Excepting SN3 and SNP3.) (Loosen counter-sunk screws and cap bolts, then turn Blade Holder Plate together with Piston and Ring to the desired position and fix.)

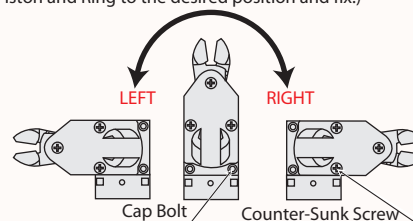

# SN TYPE SLIDING AIR CUTTERS

Blades for SN .SNP series

## STANDARD TYPE

# FN

for SN series

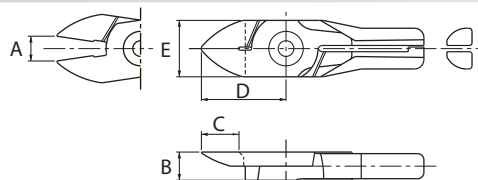

Air Pressure : 0.5MPa

Model	Blade	Cutting capacity (φmm)	Dimensions (mm)				
			A	B	C	D	E
SN1	<b>FN30</b>	1.5	2.5	7.0	11.0	24.0	12.0
SN2	<b>FN10</b>	2.0	2.8	7.0	11.0	24.0	14.0
SN3	<b>FN10</b>	2.0	3.5	7.0	11.0	24.0	14.0
SN5	<b>FN1</b>	3.0	5.5	7.0	11.0	24.0	16.0
SN10	<b>FN3</b>	4.0	7.0	9.0	11.0	27.0	19.0
SN20	<b>FN5</b>	5.0	8.5	12.0	16.0	35.0	22.0

## STANDARD TYPE

# FNP

for SNP series

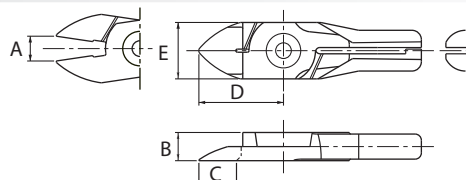

Air Pressure : 0.5MPa

Model	Blade	Cutting capacity (φmm)	Dimensions (mm)				
			A	B	C	D	E
SNP1	<b>FNP30</b>	1.5	2.5	7.0	11.0	24.0	12.0
SNP2	<b>FNP10</b>	2.0	2.8	7.0	11.0	24.0	14.0
SNP3	<b>FNP10</b>	2.0	3.5	7.0	11.0	24.0	14.0
SNP5	<b>FNP1</b>	3.0	5.5	7.0	11.0	24.0	16.0
SNP10	<b>FNP3</b>	4.0	7.0	9.0	11.0	27.0	19.0
SNP20	<b>FNP5</b>	5.0	8.5	12.0	16.0	35.0	22.0

## CRANK TYPE

# FN-C

for SN series

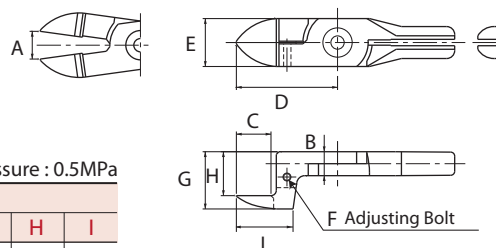

Air Pressure : 0.5MPa

Model	Blade	Cutting capacity (φmm)	Dimensions (mm)								
			A	B	C	D	E	F	G	H	I
SN1	<b>FN30C</b>	1.0	4.0	7.0	11.0	35.0	12.0	M3	18.0	14.0	19.0
SN2	<b>FN10C</b>	1.5	4.2	7.0	11.0	35.0	14.0	M3	18.0	14.0	19.0
SN3	<b>FN10C</b>	1.5	5.2	7.0	11.0	35.0	14.0	M3	18.0	14.0	19.0
SN5	<b>FN1C</b>	2.5	9.0	7.0	13.0	38.0	16.0	M3	20.0	15.0	21.0
SN10	<b>FN3C</b>	3.0	10.0	9.0	13.0	38.0	18.0	M3	21.5	16.5	21.0
SN20	<b>FN5C</b>	4.0	10.0	12.0	19.0	46.0	22.0	M3	24.0	19.0	30.0

## CRANK TYPE

# FNP-C

for SNP series

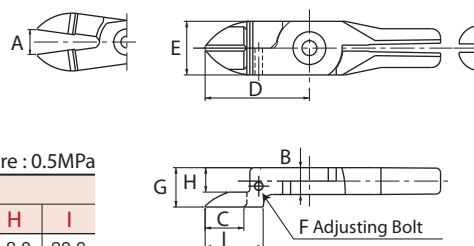
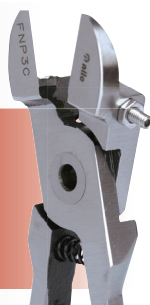

Air Pressure : 0.5MPa

Model	Blade	Cutting capacity (φmm)	Dimensions (mm)								
			A	B	C	D	E	F	G	H	I
SNP1	<b>FNP30C</b>	1.0	4.0	7.0	11.0	35.0	12.0	M3	12.0	8.0	20.0
SNP2	<b>FNP10C</b>	1.5	4.2	7.0	11.0	35.0	14.0	M3	12.0	8.0	20.0
SNP3	<b>FNP10C</b>	1.5	5.2	7.0	11.0	35.0	14.0	M3	12.0	8.0	20.0
SNP5	<b>FNP1C</b>	2.5	8.6	7.0	14.0	37.0	16.0	M3	12.2	7.2	22.0
SNP10	<b>FNP3C</b>	3.0	9.8	9.0	13.0	35.0	18.0	M3	13.2	8.2	20.0
SNP20	<b>FNP5C</b>	4.0	10.0	12.0	18.0	42.0	22.0	M3	16.0	11.0	27.0

# SN TYPE SLIDING AIR CUTTERS

Blades for SN .SNP series

## CENTER TYPE

### FN-K

for SN series

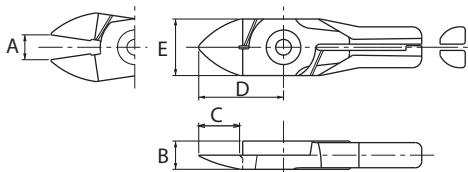

Air Pressure : 0.5MPa

Model	Blade	Cutting capacity (φmm)	Dimensions (mm)				
			A	B	C	D	E
SN1	<b>FN30K</b>	1.5	2.5	7.0	11.0	24.0	12.0
SN2	<b>FN10K</b>	2.0	2.8	7.0	11.0	24.0	14.0
SN3	<b>FN10K</b>	2.0	3.5	7.0	11.0	24.0	14.0
SN5	<b>FN1K</b>	3.0	5.5	7.0	11.0	24.0	16.0
SN10	<b>FN3K</b>	4.0	7.5	9.0	11.0	27.0	19.0
SN20	<b>FN5K</b>	5.0	8.5	12.0	16.0	35.0	22.0

## LONG TYPE

### FN-L

for SN series

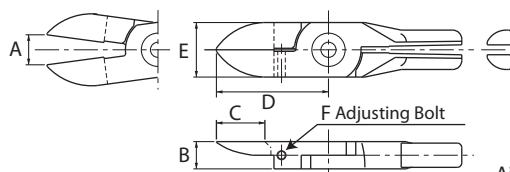
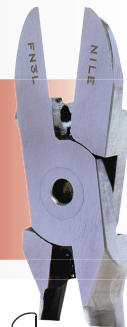

Air Pressure : 0.5MPa

Model	Blade	Cutting capacity (φmm)	Dimensions (mm)					
			A	B	C	D	E	F
SN1	<b>FN30L</b>	1.5	4.0	7.0	16.0	33.0	12.0	M3
SN2	<b>FN10L</b>	1.5	3.5	7.0	16.0	33.0	14.0	M3
SN3	<b>FN10L</b>	2.0	5.5	7.0	16.0	33.0	14.0	M3
SN5	<b>FN1L</b>	3.0	8.0	7.0	16.0	33.0	16.0	M3
SN10	<b>FN3L</b>	3.5	9.5	9.0	16.0	37.0	18.0	M3
SN20	<b>FN5L</b>	4.5	10.0	12.0	21.0	45.0	22.0	M3

## CARBIDE TIPPED TYPE

### ZFN

for SN series

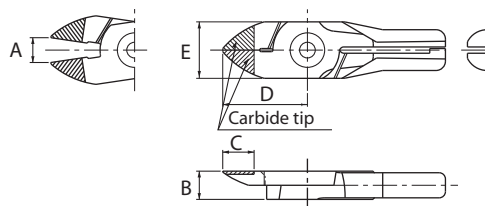

Air Pressure : 0.5MPa

Model	Blade	Cutting capacity (φmm)	Dimensions (mm)				
			A	B	C	D	E
SN1	<b>ZFN30</b>	1.5	2.5	7.0	11.0	24.0	12.0
SN2	<b>ZFN10</b>	2.0	2.8	7.0	11.0	24.0	14.0
SN3	<b>ZFN10</b>	2.0	3.5	7.0	11.0	24.0	14.0
SN5	<b>ZFN1</b>	3.0	5.5	7.0	11.0	24.0	16.0
SN10	<b>ZFN3</b>	4.0	7.0	9.0	10.0	27.0	19.0
SN20	<b>ZFN5</b>	5.0	8.5	12.0	16.0	35.0	22.0

## CARBIDE TIPPED TYPE

### ZFNP

for SNP series

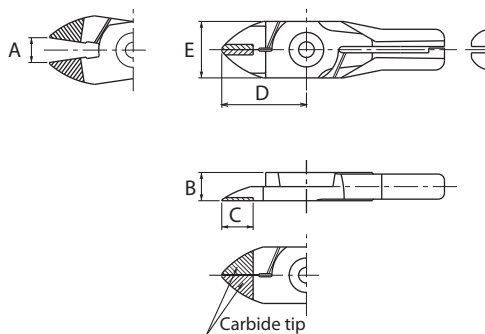

Air Pressure : 0.5MPa

Model	Blade	Cutting capacity (φmm)	Dimensions (mm)				
			A	B	C	D	E
SNP1	<b>ZFNP30</b>	1.5	2.5	7.0	11.0	24.0	12.0
SNP2	<b>ZFNP10</b>	2.0	2.8	7.0	11.0	24.0	14.0
SNP3	<b>ZFNP10</b>	2.0	3.5	7.0	11.0	24.0	14.0
SNP5	<b>ZFNP1</b>	3.0	5.5	7.0	11.0	24.0	16.0
SNP10	<b>ZFNP3</b>	4.0	7.0	9.0	10.0	27.0	19.0
SNP20	<b>ZFNP5</b>	5.0	8.5	12.0	16.0	35.0	22.0



nile air tools

# SLIDE & CUT AIR CUTTERS

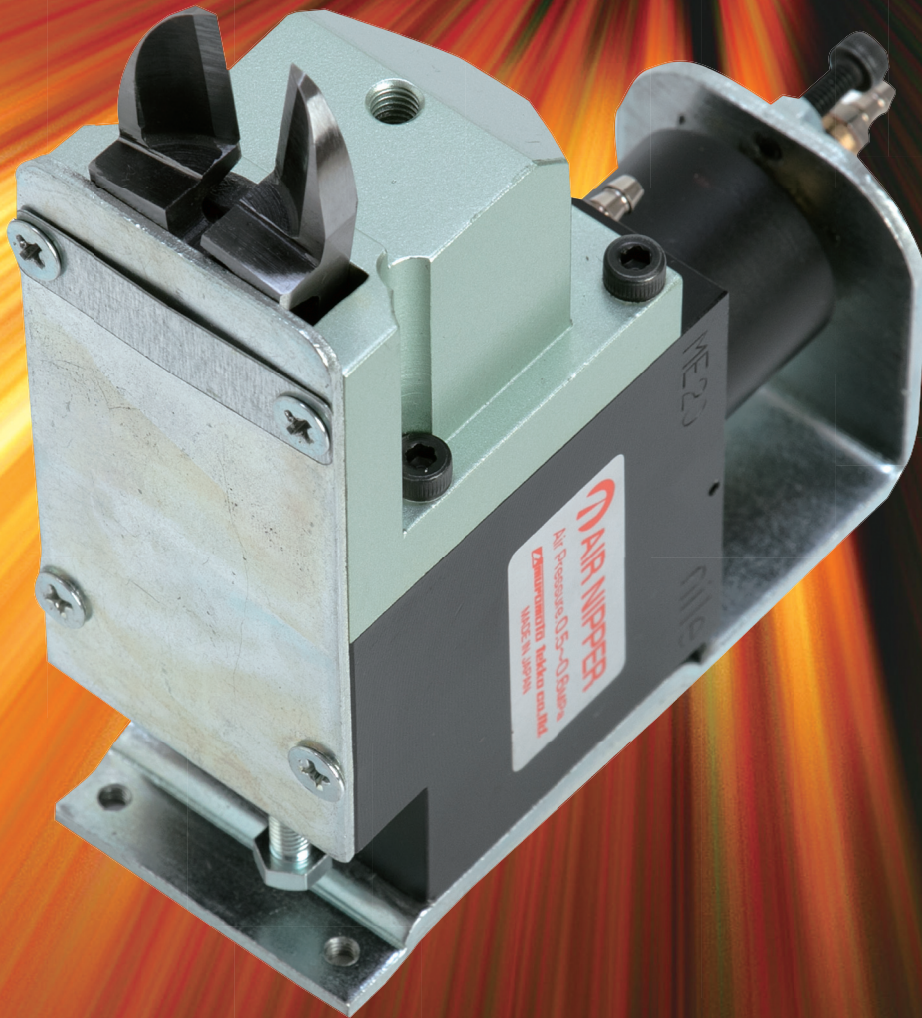

# SLIDE & CUT AIR CUTTERS

## ME Type

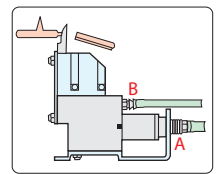
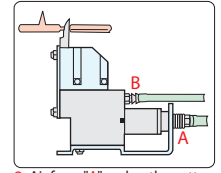
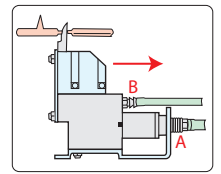
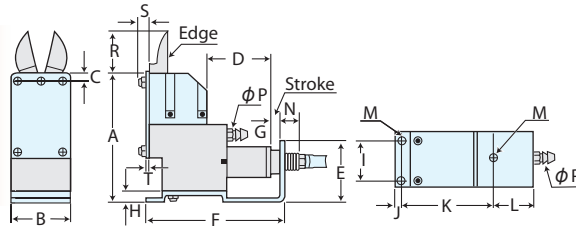
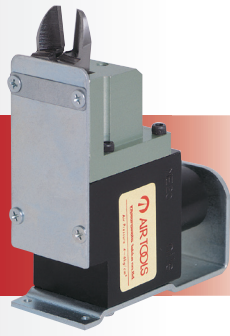

## ML Type

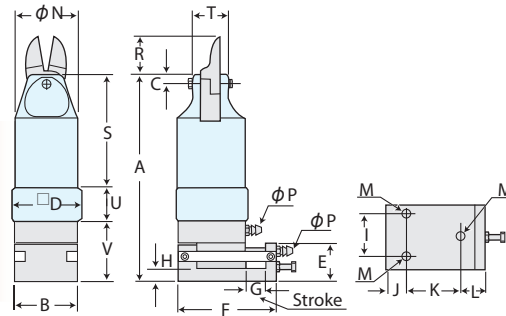

### ME type specification

Model (less blade)	Weight (g)	Air consumption (cm <sup>3</sup> /stroke)	Air pressure (MPa)	Blade	Plastic (φmm)	Dimensions (mm)																			
						A	B	C	D	E	F	G	H	I	J	K	L	M	N	P	R	S	T	U	V
ME3	170	16	0.4~0.5	F10E,F10EK	1.0	77.2	20	8	33	34.2	71.2	3	6.2	14	2.5	50	18.7	M3	12.1	4	21	3.3	2	-	-
ME5	290	32	0.4~0.5	F1E,F1EK	1.2	79.2	29	9	30	31.2	76.2	3	6.2	22	4	50	22.2	M3	12.1	4	21	4	2	-	-
ME10	540	74	0.4~0.5	F3E,F3EK	2.5	102.2	35	10	39	42.2	88.2	3	6.2	26	5	50	33.2	M3	13	4	21	4	2	-	-
ME20	810	138	0.5~0.6	F5E,F5EK	4.5	116.2	44	13	42	48.2	103.2	5	6.2	34	5	85	13.2	M4	13	4	27	2.3	2	-	-
ME30	1,490	272	0.5~0.6	F9E,F9EK	5.0	149.2	56	15	51	64.2	127.2	5	6.2	40	7	85	35.2	M4	13	4	50	3.3	3	-	-

### ML type specification

Model (less blade)	Weight (g)	Air consumption (cm <sup>3</sup> /stroke)	Air pressure (MPa)	Blade	Plastic (φmm)	Dimensions (mm)																			
						A	B	C	D	E	F	G	H	I	J	K	L	M	N	P	R	S	T	U	V
ML10	340	117	0.4~0.5	F3S	4.0	128	35	7	36	31	63	10	8	26	11	31	21	M3	35	4	19	71	18	16	41
ML20	500	282	0.5~0.6	F5S	7.0	143	44	9	45	31	64	10	8	26	11	36	17	M4	44	4	26	79	24	23	41
ML30	870	646	0.5~0.6	F9PS	10.0	184	55	15	56	33	76	10	8	26	14	38	24	M4	55	4	50	123	34	18	43

## MG Type

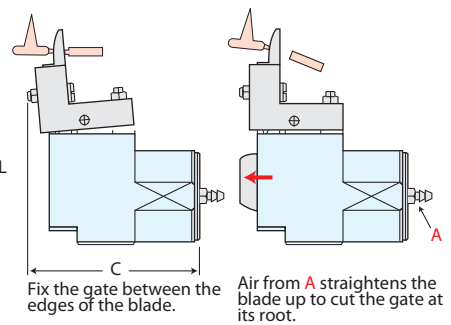
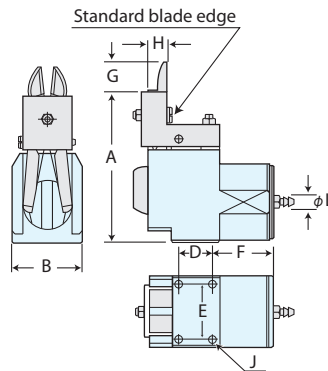
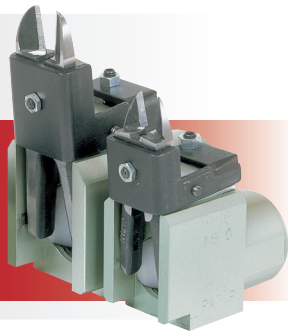

### MG type specification

Model (less blade)	Weight (g)	Air consumption (cm <sup>3</sup> /stroke)	Air pressure (MPa)	Blade	Plastic (φmm)	Dimensions (mm)									
						A	B	C	D	E	F	G	H	J	L
MG3	80	21	0.4~0.5	FG10,FG10K	2.0	50	20	60	16	14	25	15	7	M3	4
MG10	230	70	0.4~0.5	FG3,FG3K	4.0	73	35	73	20	27	29	17.5	9	M3	4
MG20	420	213	0.5~0.6	FG5,FG5K	6.0	95	46	89	21	36	39	19	12	M4	4

(mm)					(mm)				F-E, F-S, FG-		F-EK, FG-K		F-K Type Blade	
Blade	a	b	c	d	Blade	a	c	d	a	b	a	b	d	Edge
F10E, F10EK	24	13	3.5	7	FG10	24	4	7						
F1E, F1EK	24	12	5.5	7	FG10K	24	4	7						
F3E, F3EK	27	13	7	9	FG3	27	7	9						
F5E, F5EK	35	18	9	12	FG3K	27	7	9						
F9E, F9EK	65	39	15	17	FG5	34	8	12						
F3S	27	13	5	9	FG5K	34	8	12						
F5S	35	16	9~10	12										
F9PS	65	37	16	17										





nile air tools

# STAND-HOLDER FOOT VALVE TIMING UNIT

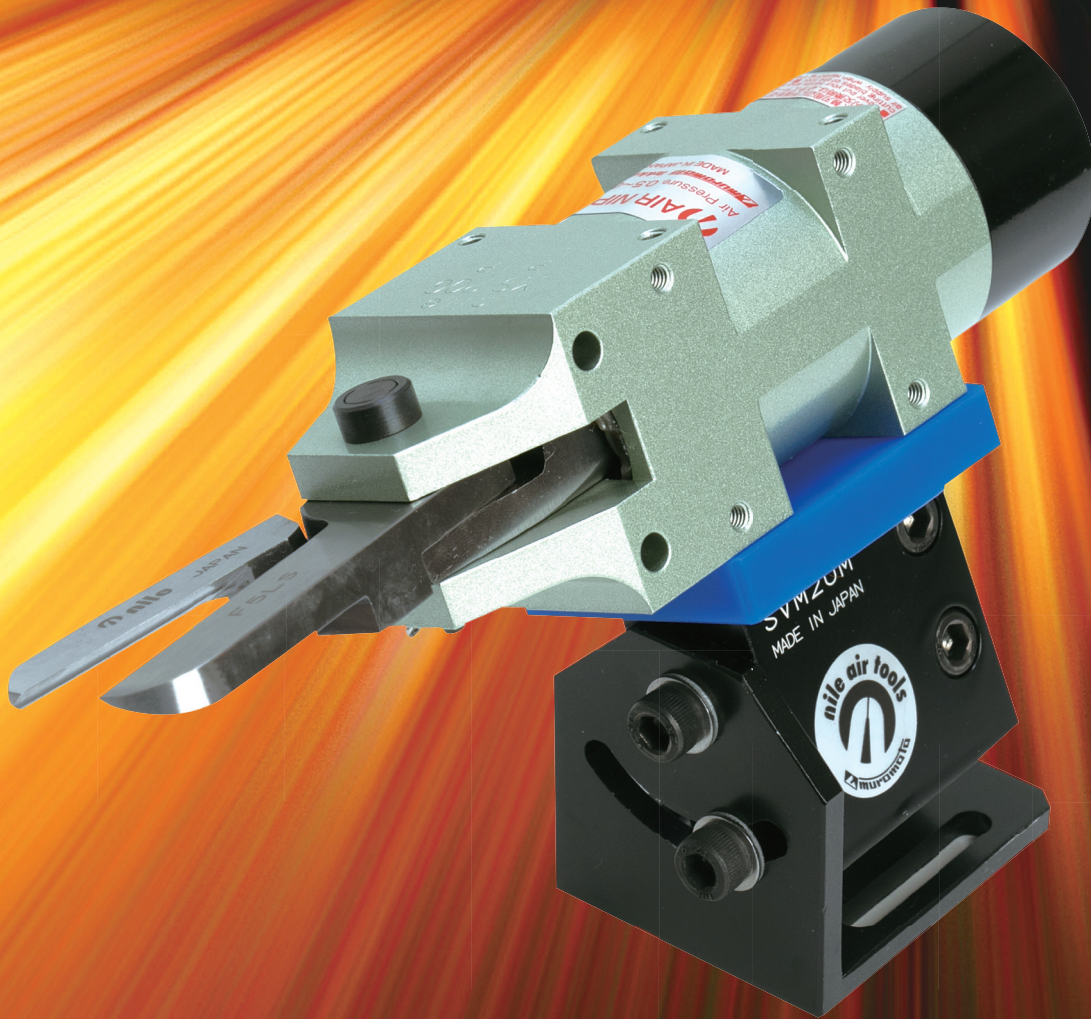

# STAND-HOLDER

## MACHINE-INSTALLATION

### SVM Type

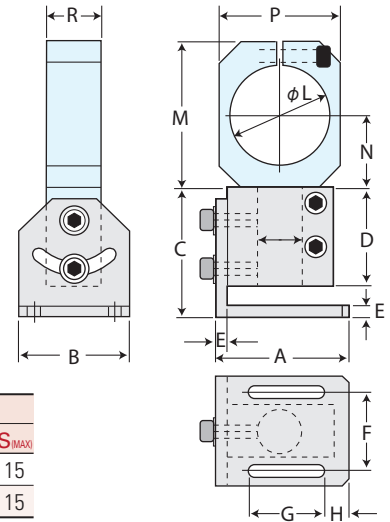
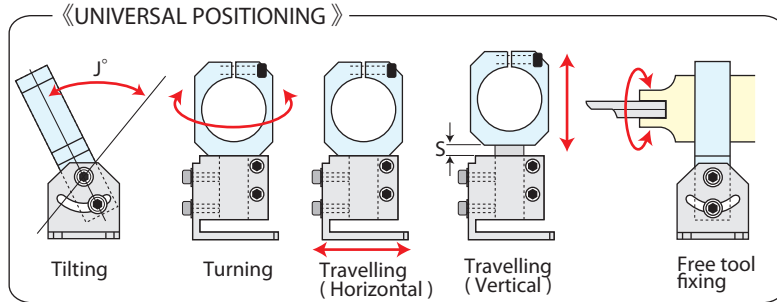
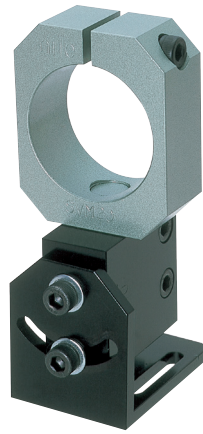

#### SVM type specification

Model	Weight (g)	Applicable air cutters of round body	Dimensions (mm)															
			A	B	C	D	E	F	G	H	J <sub>MAX</sub>	K	L	M	N	P	R	S <sub>MAX</sub>
SVM20	325	MR20M series of body $\phi 45$	60	50	59	45	5	36	34	11	90°	20	45.1	67	33	55	24	15
SVM30	367	MR30AM series of body $\phi 56$	60	50	59	45	5	36	34	11	90°	20	56.1	78	38	70	24	15

## MACHINE-INSTALLATION

### SVM-M Type

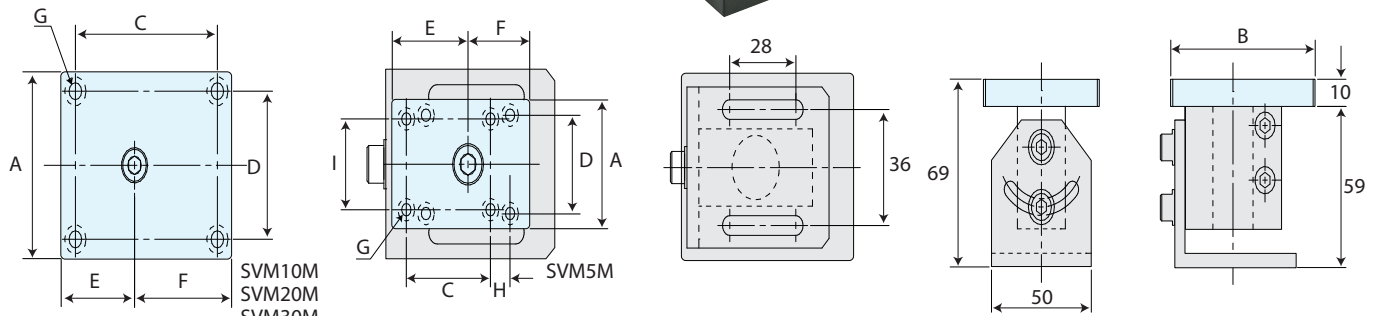
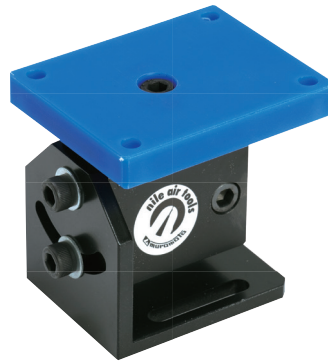

#### SVM-M type specification

Model	Weight (g)	Applicable air cutters of round body	Dimensions (mm)									
			A	B	C	D	E	F	G	H	I	
SVM5M	310	MS5, MSP5, MS5G, MSP5G, WS5, AH5, AH5D	34	49	30	26	27	22	8- $\phi 3.3$	12	24	
SVM10M	310	MS10, MSP10, MS10G, MSP10G, MS10AG, MSP10AG, MS10V, MSB10, WS10, AM10, AH8, AH8D	38	46	30	28	20	26	4- $\phi 4.3$	-	-	
SVM20M	327	MS20, MSP20, MS20G, MSP20G, MS20V, MSB20, WS20, AM20, AH20	47	58	40	36	27	31	4- $\phi 4.3$	-	-	
SVM30M	340	MS20, MSP20, MS20G, MSP20G, MS20V, MSB20, WS20, AH30	58	72	60	46	31	41	4- $\phi 5.3$	-	-	

# STAND-HOLDER/FOOT VALVE/ TIMING UNIT

## FIXING STAND

### CTD Type

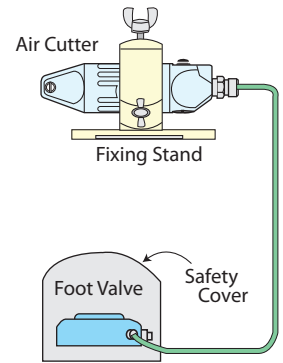
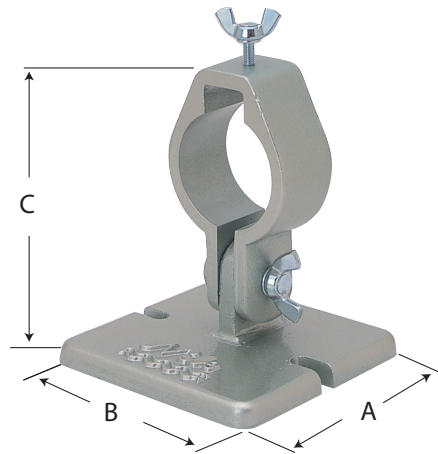

### CTD type specification

Model	Weight (g)	A (mm)	B (mm)	C (mm)	Applicable tools
<b>CTD20</b>	600	140	120	117.5	For MR20,MR20M
<b>CTD30</b>	500	140	120	117.5	For MR30A,MR30AM

## FOOT VALVE

### FB70S

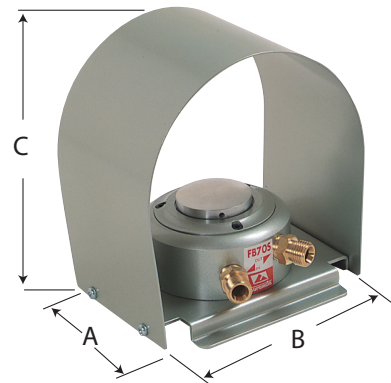

### FB70S specification

Model	Weight (g)	A (mm)	B (mm)	C (mm)
<b>FB70S</b>	970	110	122	145

## TIMING UNIT

### TU01

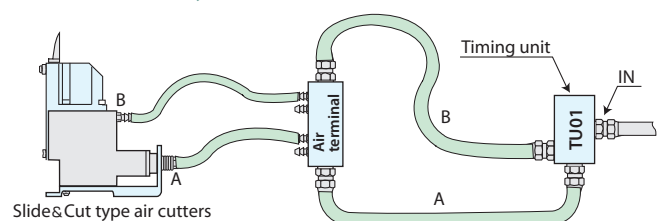
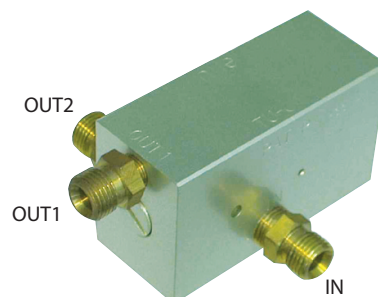

Through the Timing Unit, air from "IN" valve firstly flows into A-branch to move the tool body, and secondly into B-branch after a short interval to actuate the blade.



nile air tools

# AIR HEAT CUTTERS



# AIR HEAT CUTTERS

Cutting blades are heated for easy cutting.

- Suitable for cutting fragile materials such as Acryl/Glass Resin, etc .
- Square body is easy to be set to stands or machinery.
- Indispensable for resin molding works.
- Operate through solenoid valve or foot-valve(FB70S).
- Cutting speed can be adjusted through Air Regulator.

## MACHINE-FITTING TYPE

### AH Type Transformer TRF25

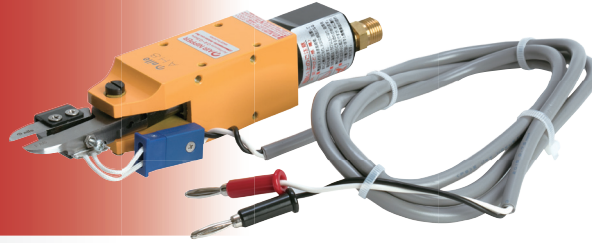

### ● Transformer



TRF25 (for AH5,AH8)

#### AH type specification

Model (less blade)	Weight (g)	Air consumption (cm <sup>3</sup> /stroke)	Cutting capacity (φmm)	Dimensions (mm)															
				A	B	C	D	E	F	G	H	J	K	L	M	N	P	R	
AH5	210	64	3.0	76	32	30	14	19	26	-	34	31	M3D7	-	21	7	7	-	
AH8	290	116	4.0	94	36	30	18	23	28	-	36	35	M4D6.5	-	23	9	8	-	

Model	Input power	Output power	Length of cord (m)
TRF25	AC100V50•60HZ	30VA MAX	1.85

## MACHINE-FITTING TYPE

### AH-D Type Transformer TRF100D

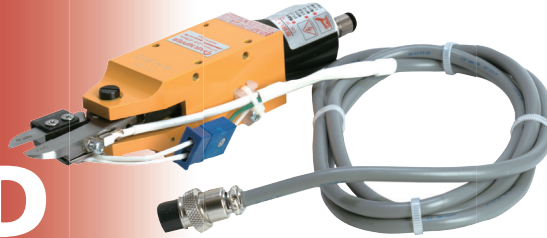

### ● Digital Indication type transformer



TRF100D (for AH5D,AH8D)

#### AH-D type specification

Model (less blade)	Weight (g)	Air consumption (cm <sup>3</sup> /stroke)	Cutting capacity (φmm)	Dimensions (mm)															
				A	B	C	D	E	F	G	H	J	K	L	M	N	P	R	
AH5D	210	64	3.0	76	32	30	14	19	26	-	34	31	M3D7	-	21	7	7	-	
AH8D	290	116	4.0	94	36	30	18	23	28	-	36	35	M4D6.5	-	23	9	8	-	

  

Model	Input power	Output power	Length of cord (m)
TRF100D	AC100V50•60HZ	30VA MAX	1.83

# HEATER



W-19 (for AH,AH-D)

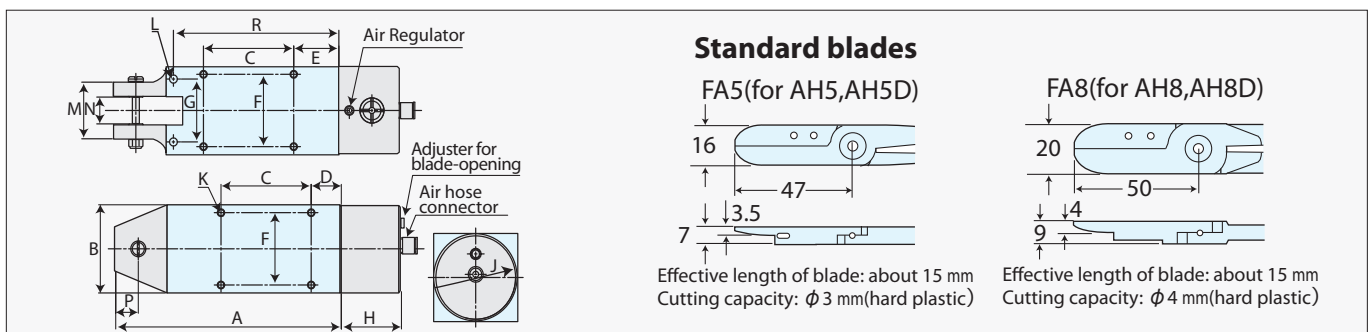

# AIR HEAT CUTTERS

- Double-heater can set temperature in wide range between 70~200°C to fit each resin gate at the most suitable temperature.
- 3 models of replaceable blades are available to suite various kinds of gate cutting jobs.

## MACHINE-FITTING TYPE

# AH Type Transformer HTR100W



### Digital Indication type transformer

The digital indication type transformer (HTR100W) must be used with these Double-heater type Air Heat-Nippers.



HTR100W (for AH20,AH30)

### AH type specification

Model (less blade)	Weight (g)	Air consumption (cm <sup>3</sup> /stroke)	Cutting capacity (φmm)	Dimensions (mm)															
				A	B	C	D	E	F	G	H	J	K	L	M	N	P	R	
AH20	505	262	6.0	109	45	40	19	24	36	30	40	44	M4D8	5.3	26	12	9	81	
AH30	930	621	7.0	150	56	60	20	30	46	40	40	55	M5D11	5.3	36	17	15	110	

Model	Input power	Output power	Length of cord	Weight	Adjustment range of temperature
HTR100W	AC100V	64VA(MAX)	1.85m	1,200g	70~200°C

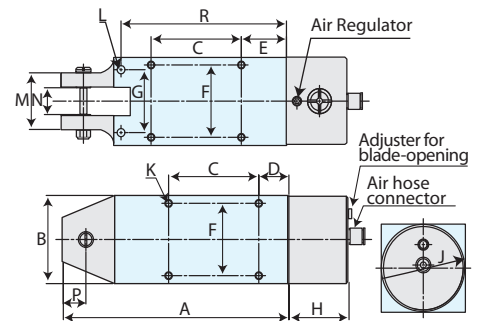

# HEATER



W-19W

# BLADE

## Straight type FA20S, FA30S

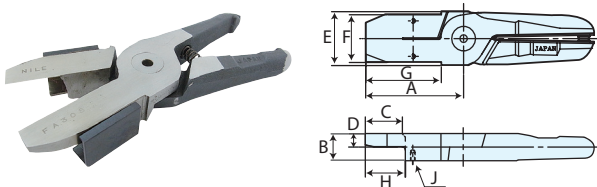

Model	Blade	A	B	C	D	E	F	G	H	J	K
AH20	FA20S	70	12	20	6	36	23	22	22	M3D5	—
AH30	FA30S	66	17	25	8.5	35	31	51	27	M3D5	—

## L type FA20L, FA30L

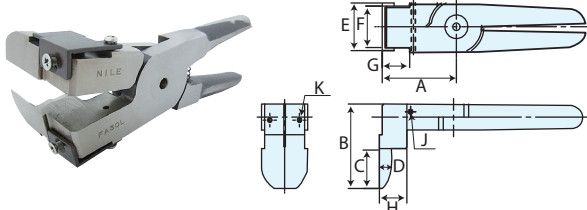

Model	Blade	A	B	C	D	E	F	G	H	J	K
AH20	FA20L	36	49	20	5	23	19	18.5	18	M3D6	M3D8
AH30	FA30L	50	55	25	8	31	27	18.5	18.5	M3	M3D8

## Crank type FA20C, FA30C

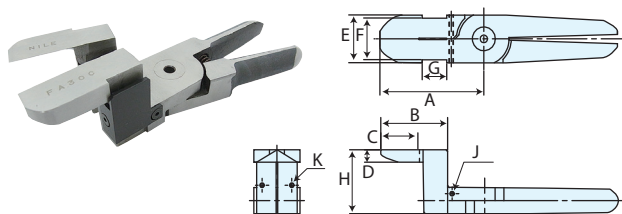

Model	Blade	A	B	C	D	E	F	G	H	J	K
AH20	FA20C	55	37	20	5	23	19	16.5	30	M3D6	M3D8
AH30	FA30C	70	45	25	8	31	27	16.5	41.5	M3	M3D8



nile air tools

# AIR SHOT-HAMMER



# AIR SHOT-HAMMER

These shot-hammers simplify and quicken various inserting jobs of pins, bushings, collar caps, oil seals, bearings, etc. in assembly lines.

## RVS85

Standard rivet snap

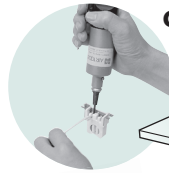
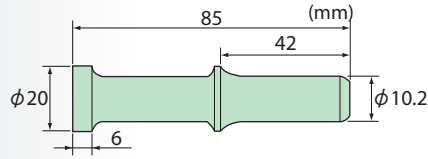

**CB13S**  
Punching a hole on a rubber sheet.



## RH25

**Standard** Single Blow

Recommended Air pressure:  
0.5~0.7MPa



Overall length	213mm
Weight	900g
Grip size	φ37mm
Air consumption	135cm <sup>3</sup> /stroke
Blowing power	(Approx.) 360N

● Each operation of the lever generates one blow.

## RH80

**Standard** Single Blow

Recommended Air pressure:  
0.5~0.7MPa



Overall length	254mm
Weight	1,300g
Grip size	φ45mm
Air consumption	135cm <sup>3</sup> /stroke
Blowing power	(Approx.) 370N

● Each operation of the lever generates one blow.

## RH90

**Standard** Single Blow

Recommended Air pressure:  
0.5~0.7MPa



Overall length	328mm
Weight	1,600g
Grip size	φ43mm
Air consumption	651cm <sup>3</sup> /stroke
Blowing power	(Approx.) 460N

● Each operation of the lever generates one blow.

## RH100Z

**Heavy-duty** Single Blow

Recommended Air pressure:  
0.5~0.7MPa



Overall length	328mm
Weight	2,100g
Grip size	φ43mm
Tank size	φ72mm
Air consumption	651cm <sup>3</sup> /stroke
Blowing power	(Approx.) 470N

● Each operation of the lever generates one blow.  
● It can be used for stamping, riveting and chipping, by changing the attachments.

## RH200

**Heavy-duty** Single Blow

Recommended Air pressure:  
0.5~0.7MPa

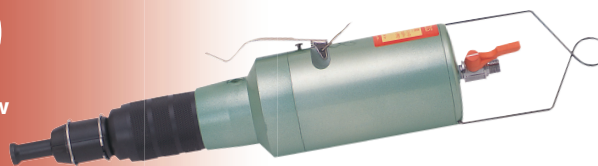

Overall length	341mm
Weight	2,100g
Grip size	φ51mm
Tank size	φ86mm
Air consumption	653cm <sup>3</sup> /stroke
Blowing power	(Approx.) 620N

● Each operation of the lever generates one blow.  
● It can be used for stamping, riveting and chipping, by changing the attachments.

## CB13S

**Small-sized** Single Blow

Recommended Air pressure:  
0.5~0.6MPa



Overall length	175mm
Weight	310g
Grip size	φ30mm
Air consumption	54cm <sup>3</sup> /stroke

● Each operation of the lever generates one blow.

## CB13L

**Small-sized** Single Blow

Recommended Air pressure:  
0.5~0.6MPa



Overall length	215mm
Weight	500g
Grip size	φ36mm
Air consumption	105cm <sup>3</sup> /stroke

● Each operation of the lever generates one blow.





nile air tools

# AIR SHEARS AIR PLATE SHEARS AIR MULTI-PURPOSE SCISSORS



# AIR SHEARS

## AIR SHEARS

### AS Type Standard

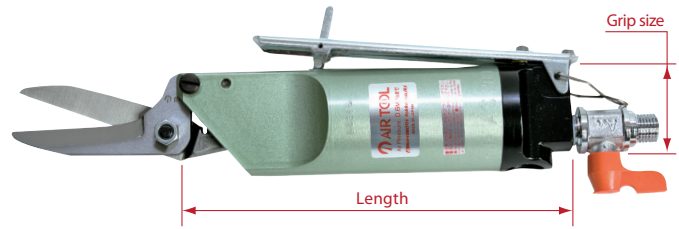

### ASP Type Heavy-duty



#### AS type specification

Model (less blade)	Length (mm)	Weight (g)	Grip size $\phi$ (mm)	Air consumption (cm <sup>3</sup> /stroke)	Air pressure (MPa)
AS100	140	230	36	137	0.5~0.6
AS200	182	500	45	227	0.5~0.6

#### ASP type specification

Model (less blade)	Length (mm)	Weight (g)	Grip size $\phi$ (mm)	Air consumption (cm <sup>3</sup> /stroke)	Air pressure (MPa)
ASP150	212	300	36	274	0.5~0.6
ASP250	269	720	45	508	0.4~0.6

#### AS type Blade cutting capacity

Model	Blade	Plata (mm)
AS100	No.100S, No.100R	0.5x15
AS200	No.200S, No.200R	0.8x25 1.0x10

#### ASP type Blade cutting capacity

Model	Blade	Plata (mm)
ASP150	No.100S, No.100R	0.5x20
ASP250	No.200S, No.200R	0.8x25 1.0x15

## AIR SHEARS MACHINE-FITTING TYPE

### AM Type

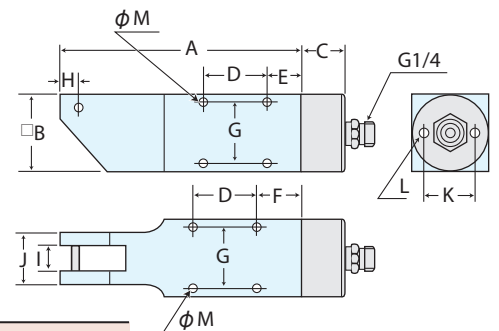
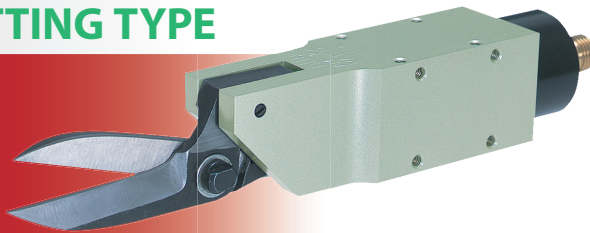

#### AM type specification

Model (less blade)	Weight (g)	Dimensions (mm)												
		A	B	C	D	E	F	G	H	I	J	K	L	M
AM3	103	90	20	21	40	19	24	16	7	7	20	-	-	M3
AM10	296	109	36	20	30	18	23	28	5	10	26	24	M4	M4
AM20	507	139	45	20	40	19	24	36	6	10	26	30	M5	M4

#### AM type Blade cutting capacity

Model	Blade	Plata (mm)	Copper wire ( $\phi$ mm)
AM3	No.30S	-	0.8
AM10	No.100S, No.100R	0.5x15	-
AM20	No.200S, No.200R	0.8x25 1.0x10	-

#### Shape of Blades

No.30S, No.100S, No.200S

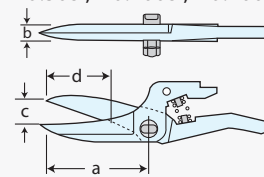

No.100R, No.200R

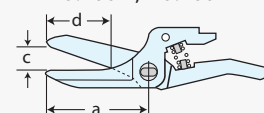

Blade	a	b	c	d
No.30S	33	7	6	20
No.100S	66	10	15	37
No.200S	66	10	15	37
No.100R	62	10	12.5	34
No.200R	62	10	12.5	34

# AIR PLATE SHEARS/ AIR MULTI-PURPOSE SCISSORS

## AIR PLATE SHEARS

### PSH05 MINI PLATE SHEARS

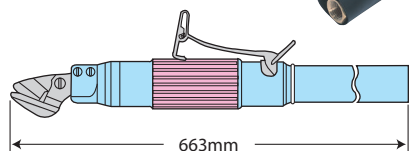

## AIR PLATE SHEARS

### PSH10 PLATE SHEARS

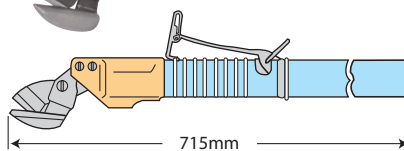

#### PSH type specification

Model (less blade)	Length (mm)	Weight (g)	Grip size $\phi$ (mm)	Cutting speed (min.)	Air consumption (ℓ/min.)	Air pressure (MPa)
PSH05	173	700	40	1,220	300	0.55~0.65
PSH10	224	1,230	40	1,900	450	0.55~0.65

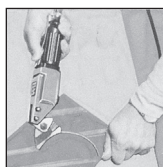
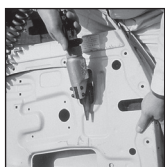

#### PSH05 type Blade cutting capacity (mm)

Model	Blade	Metal Plate	Aluminum Plate	Rubber Resin Plate
PSH05	E250	0.6	0.8	2.0
	E250S			
	E250H			

"Max. Cutting Capacity" is not definite but just a rough guidance for tool choice.

#### PSH10 type Blade cutting capacity (mm)

Model	Blade	Metal Plate	Aluminum Plate	Resin Plate
PSH10	E300	1.2	1.2	2.5 (W/E300)
	E300S			
	E300H (High-speed steel made)			
	E300ZN			

"Max. Cutting Capacity" is not definite but just a rough guidance for tool choice.

## AIR MULTI-PURPOSE SCISSORS

### GS01 GS02



Versatile to cut a wide variety of materials, such as light sheet metal, plastics and carpet, etc.

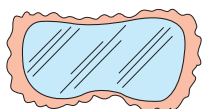

Suitable for cutting or trimming thin metal sheet, vinyl cloth, paper, etc.

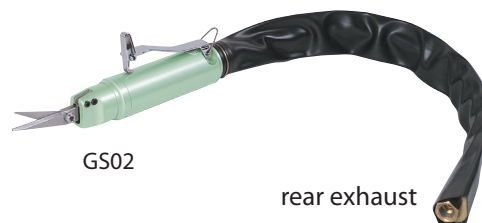

#### GS01 GS02 specification

Model (less blade)	Length (mm)	Weight (g)	Grip size $\phi$ (mm)	Air consumption (ℓ/min.)	Air pressure (MPa)
GS01/GS02	140	500	36	450	0.35~0.6

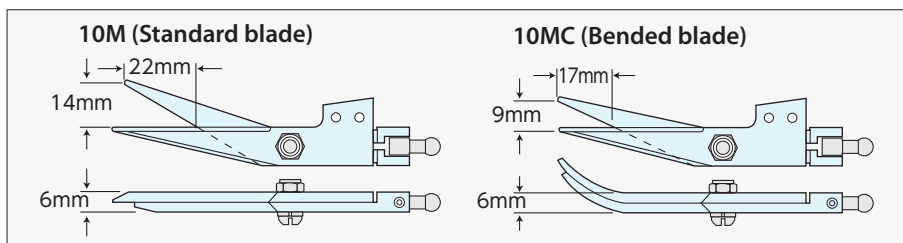



nile air tools

# AIR FIL-SAWS



# AIR FIL-SAWS

Light in weight and silent in operation.

## AF5 Type

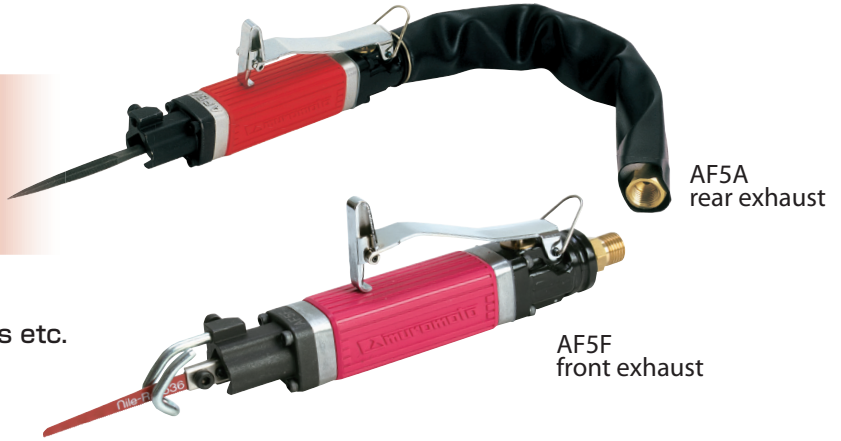

### APPLICATIONS



- ◆ Cutting auto-panel, baffles and members etc.
- ◆ Cutting urethane bumpers.
- ◆ Finishing dies.
- ◆ Chamfering parts after machining.
- ◆ Deburring die-castings.

### AF5 type specification

Recommended air pressure : 0.65MPa

Model	Length (mm)	Weight (g)	Grip size □(mm)	Stroke (mm)	Reciprocating speed(strokes/min.)	Air consumption (ℓ/min.)	Cutting capacity (Metal plate) mm/min(approx.)
AF5A	158	380	29×29	5	3,500	200	1mm Plate 500
AF5F	158	380	29×29	5	3,500	200	1mm Plate 500

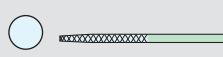
Teeth/ inch	Standard saw blade Model&Shape
36	R0536 

Model	Files Model&Shape
AFF50 Flat	
AFR50 Round	
AFT50 Triangular	

### File (OPTION)

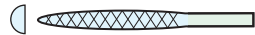
Model	Shape
AFH50	

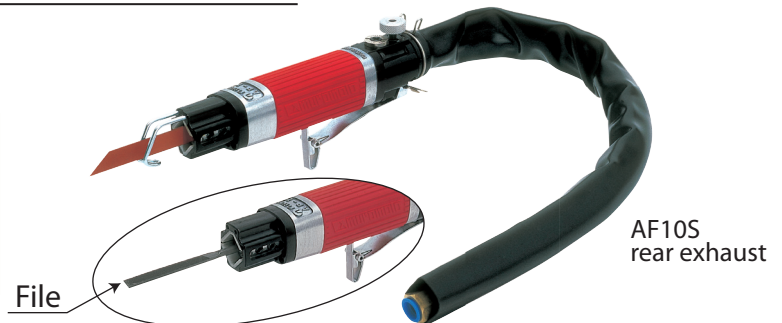

## AF Type





### AF type specification



Recommended air pressure : 0.65MPa

Model	Length (mm)	Weight (g)	Grip size □(mm)	Stroke (mm)	Reciprocating speed(strokes/min.)	Air consumption (ℓ/min.)	Cutting capacity (Metal plate) mm/min(approx.)
AF7	180	650	39×37	7	6,900	280	1mm Plate 900 3mm Plate 135
AF7S	180	650	39×37	5	8,400	280	1mm Plate 850 3mm Plate 135
AF10S	201	750	39×37	10	5,500	280	1mm Plate 1,000 3mm Plate 180

Teeth/ inch	Standard saw blade Model&Shape
32	AF1032 
	R1032 

### Saw Blade (OPTION)

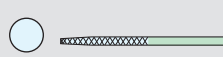
Model	Application	Teeth/ inch	Shape
SR1036	Steel (Small circle)	36	
R1010	Urethane	10	
W1014	Wood Aluminum	14	

Model	Files Shape
AFF50 Flat	
AFR50 Round	
AFT50 Triangular	



nile air tools

# MINI BELTERS AIR SQUEEZERS CABLE CUTTERS AIR TWISTER



# MINI BELTERS

## MINI BELTERS

### MB20

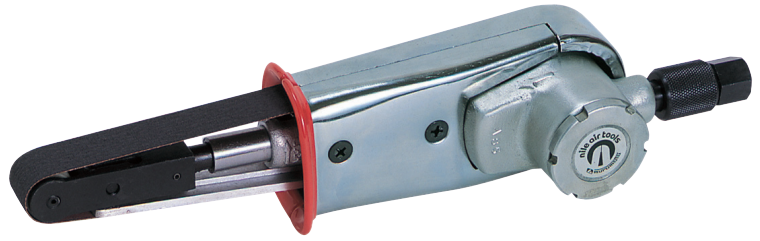

For use in limited places or for spot sanding

#### MB20 specification

Model	Length (mm)	Weight (g)	Air consumption (ℓ/min.)	Air pressure (MPa)	Free belt speed (m/min.)	Belt size (mm)	Remarks φ (mm)
MB20	290	930	300	0.5~0.6	2,200	20×500	Diameter of pulley φ21mm

## MINI BELTERS

### MB20S

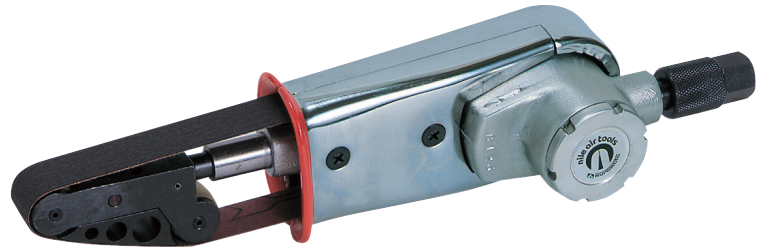

3-point belt suspension makes sanding more smooth

#### MB20S specification

Model	Length (mm)	Weight (g)	Air consumption (ℓ/min.)	Air pressure (MPa)	Free belt speed (m/min.)	Belt size (mm)	Remarks φ (mm)
MB20S	290	1,080	300	0.5~0.6	2,200	20×500	Diameter of pulley φ21mm

Product name	Model	Belt Size (mm)	Type
Belt (Per box 20pcs)	#40	20×520	MB20
	#60		MB20S
	#100		

#### ● APPLICATIONS

- ◆ Sanding for various auto-repair services such as...
  - Removing spot welding.
  - Removing paint off flat or curved surfaces.
  - Removing welding bead.
- ◆ Finishing wood work.
- ◆ Deburring small metal products.
- ◆ Removing rust.

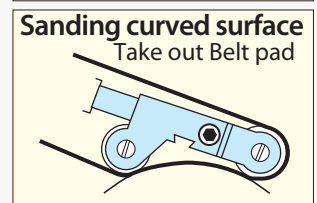
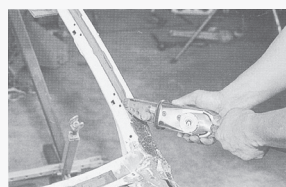
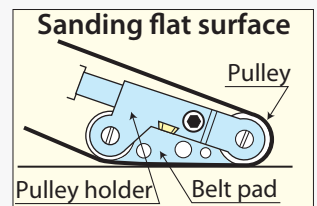
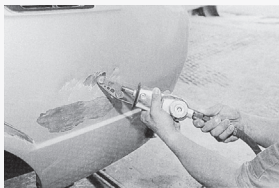

# AIR SQUEEZERS/ CABLE CUTTERS/AIR TWISTER

## AIR SQUEEZERS

# GXT1000 GXT1200

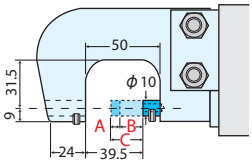
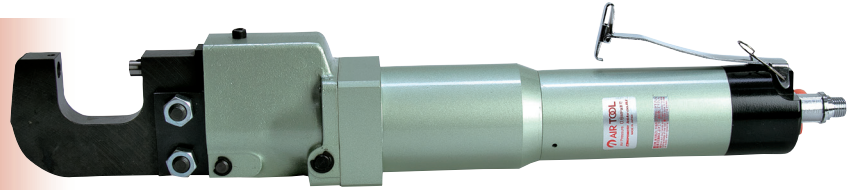

A=3.5mm (pressure power generation zone)  
B = 17mm (quick projection zone)  
C = 20.5mm (overall stroke)  
★ Attachments are optional and manufactured on demand.  
★ Use a suitable die for punching.

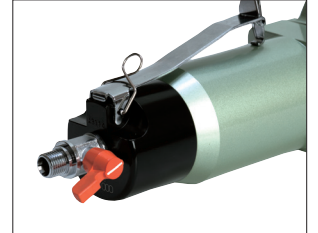
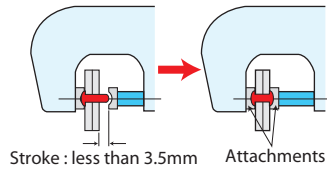

### GXT type specification

Model	Length (mm)	Weight (g)	Grip size $\phi$ (mm)	Air consumption (cm <sup>3</sup> /stroke)	Power N (approx.)	Air pressure (MPa)	Capacity (for reference)	
							Riveting	Punching holes
GXT1000	359	3,300	65	1,019	5,780	0.5~0.6	Steel rivet=less $\phi$ 2mm Aluminum rivet=less than $\phi$ 4mm	$\phi$ 4mm Holes (2mm Steel Plate)
GXT1200	472	3,800	56	1,715	8,800	0.5~0.6	Steel rivet=less $\phi$ 2mm Aluminum rivet=less than $\phi$ 5mm	$\phi$ 4mm Holes (3mm Steel Plate)

## CABLE CUTTERS

# WK Type

Cutting of iron plate. Cutting of nylon tube.  
By changing the blade, various cutting work can be done.

With safety cover

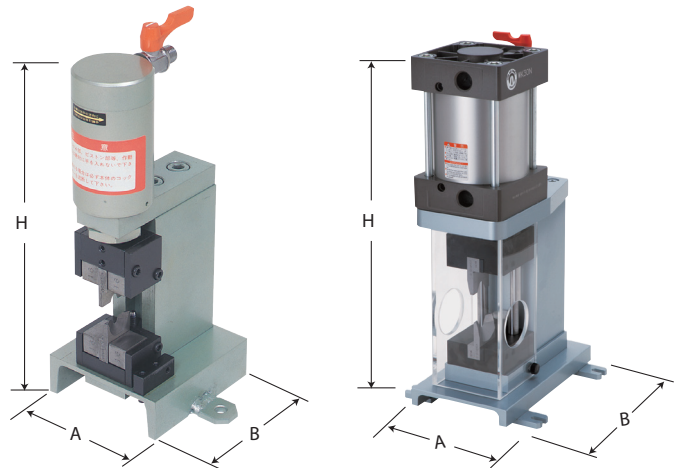

### WK type specification

Model (less blade)	Weight (kg)	Air consumption (cm <sup>3</sup> /stroke)	Air pressure (MPa)	Dimensions (mm)			Blade	Cutting capacity ( $\phi$ mm)
				A	B	H		
WK10	6	639	0.5~0.65	100	110	268.5	VOHR5	Cable : until 7mm
WK30N	21	5,000	0.5~0.65	125	216	394	VOHR10	Cable : until 30mm

## AIR TWISTER

# RC6



Easy to insert of Crimping terminal, Connection terminal and etc.

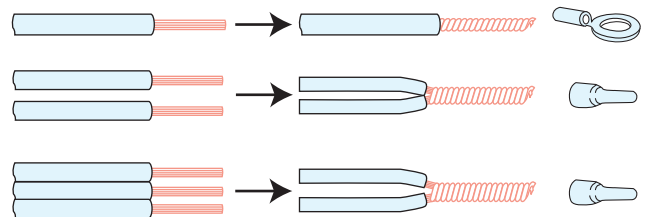

### RC6 specification

Model	Length (mm)	Weight (g)	Grip size $\phi$ (mm)	Air consumption (cm <sup>3</sup> /stroke)	Rotations Speed (min)	Twist capacity
RC6	180	830	38	45	1,900	1~5





nile air tools

# CABLE STRIPPERS

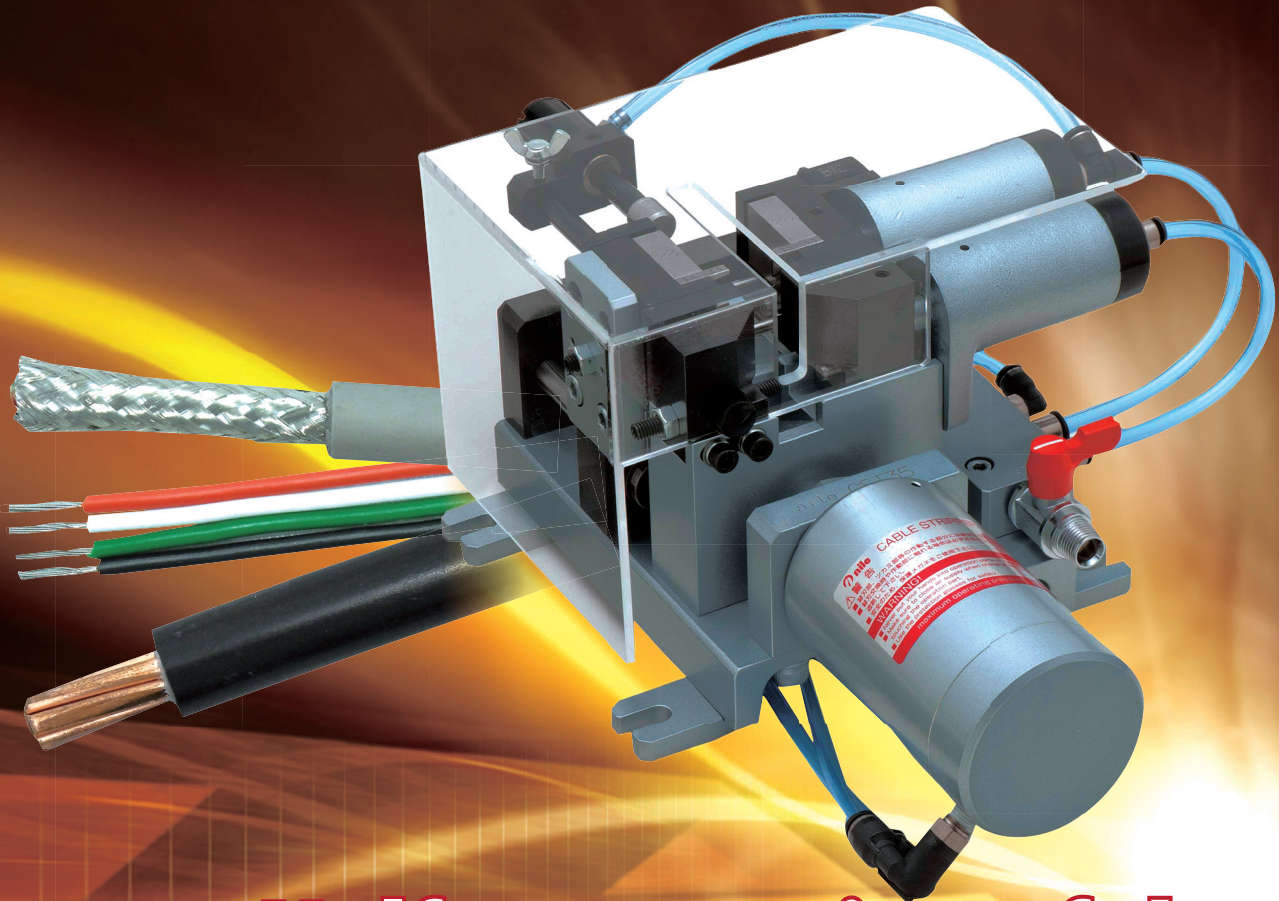

## Half automation of the electric cable stripping

It is product that can work efficiently with less investment. Anyone can easily work and can shorten a working hour.

Recommended type of industry

- Harness line processing, such as an automobile
- Electric cable processing of vehicle charging station
- Terminal processing of electric cable for houses
- Terminal processing of the household electrical appliance
- Electric cable processing of Solar-related

# CABLE STRIPPERS

Work will be easy and simple for anyone.  
It saves time and trouble stripping cables.

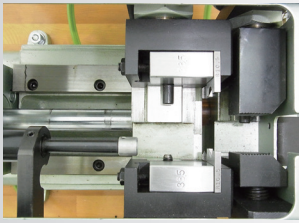

Set of spare blade

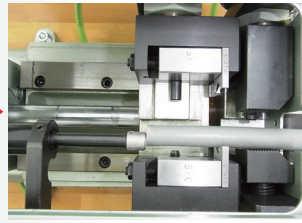

Insert the cable

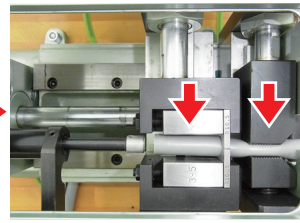

Push the foot valve

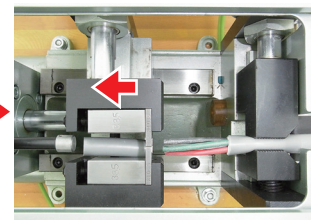

The cable is instantly stripped

## Example of application

### ● Simple stripping



By changing blades, it can support a wide variety of electric cable.

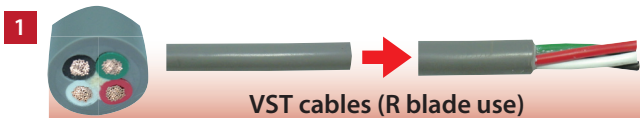

VST cables (R blade use)

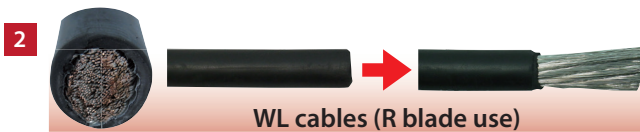

WL cables (R blade use)



Multi-core cables (R blade use)

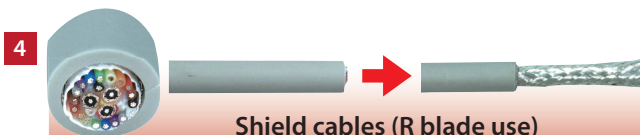

Shield cables (R blade use)

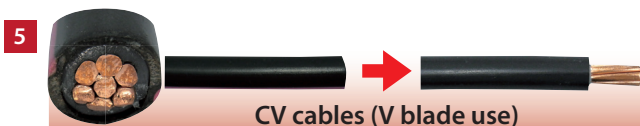

CV cables (V blade use)

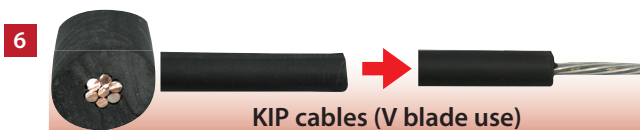

KIP cables (V blade use)

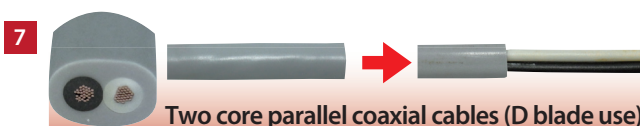

Two core parallel coaxial cables (D blade use)

※ Electric cable other than the above is also available.  
Please contact us once.

### ● Simultaneous stripping of the thin cables (S blade use)

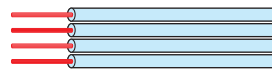

It can strip a thin cable several at the same time.



### ● 2 segment stripping (R&S blade use)

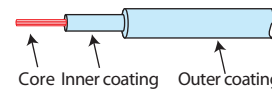

Strip inner and outer coatings at the same time.



### ● Simultaneous stripping of the line split cables (SP1 & WR blade use)

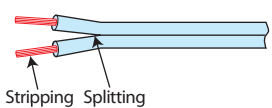

Split joined cables and strip them at the same time.



### ● Middle stripping (R blade use)

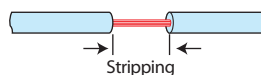

Outer coating movement method



# CABLE STRIPPERS

## Blades

R-TYPE

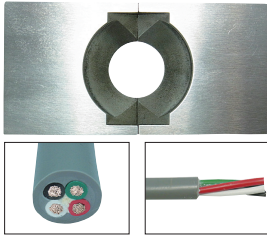

D-TYPE

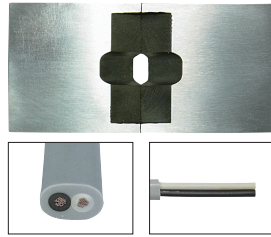

S-TYPE

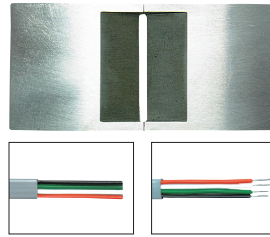

V-TYPE

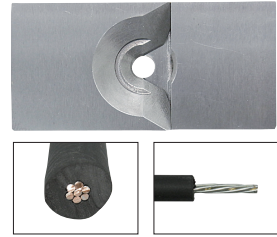

Only the CST35 has standard spare blade set

### Set items

Product for 1.25sq•2.0sq	RW1.25-2.0	1set
Product for 3.5sq•5.5sq	RW3.5-5.5	1set
Product for S0	S0	1set

With case

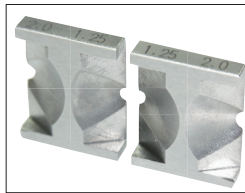
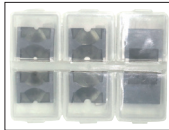

●RW1.25-2.0  
for 1.25sq•2.0sq

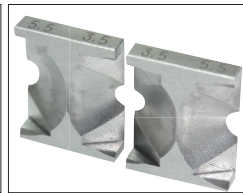

●RW3.5-5.5  
for 3.5sq•5.5sq

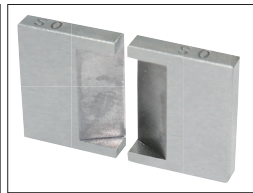

●S0  
for S zero

※It is possible to use two sizes in one set.

※Operate the stopper bolt, please use it to adjust the blade spacing.

## CST35

### For thin cable

It's suitable for the high-speed stripping of the thin cable.

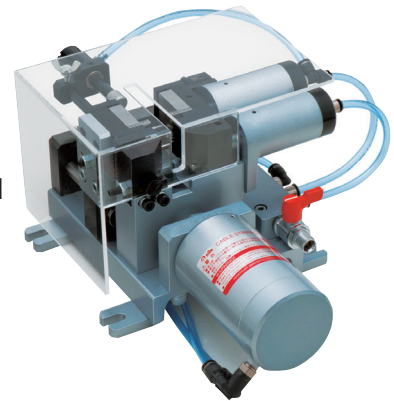

### CST35 specification

Model	Length (mm)	Weight (kg)	Height (mm)	Width (mm)	Air consumption (cm <sup>3</sup> /stroke)	Air pressure (MPa)	Stripping capacity $\phi$ (mm)	Stripping length (mm)
CST35	260	8	100	150	850	0.5~0.6	up to $\phi$ 5mm outer dia.	30

## CST100

### The most standard type

It can perform the complex stripping.

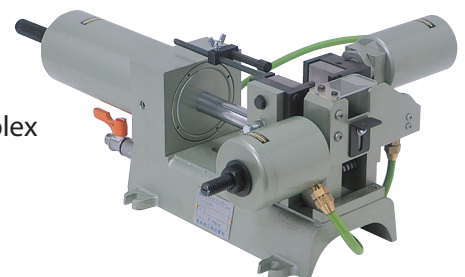

### CST100 specification

Model	Length (mm)	Weight (kg)	Height (mm)	Width (mm)	Air consumption (cm <sup>3</sup> /stroke)	Air pressure (MPa)	Stripping capacity $\phi$ (mm)	Stripping length (mm)
CST100	420	13.5	169	318	3,000	0.5~0.6	up to $\phi$ 15mm outer dia.	100

# CABLE STRIPPERS

## CST110

### Improvement of type CST100

Safety cover is attached. It can smoothen the discharge of waste.

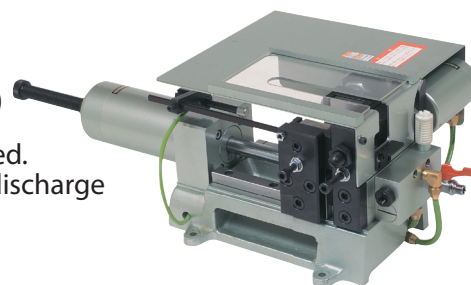

#### CST110 specification

Model	Length (mm)	Weight (kg)	Height (mm)	Width (mm)	Air consumption (cm <sup>3</sup> /stroke)	Air pressure (MPa)	Stripping capacity $\phi$ (mm)	Stripping length (mm)
CST110	470	21	200	275	3,100	0.5~0.6	up to $\phi$ 15mm outer dia.	100

## CST100L

### Long type

It is suitable for stripping long dimension cable.



#### CST100L specification

Model	Length (mm)	Weight (kg)	Height (mm)	Width (mm)	Air consumption (cm <sup>3</sup> /stroke)	Air pressure (MPa)	Stripping capacity $\phi$ (mm)	Stripping length (mm)
CST100L	785	18	155	300	5,872	0.5~0.6	up to $\phi$ 15mm outer dia.	200

## CST120

### Large type

It is suitable for stripping of large diameter cable.

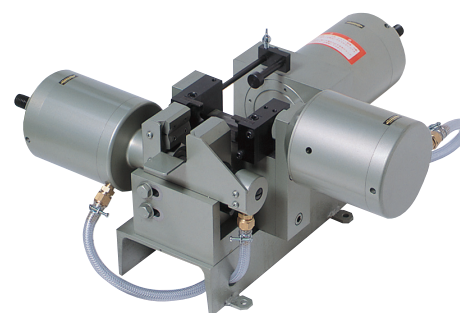

#### CST120 specification

Model	Length (mm)	Weight (kg)	Height (mm)	Width (mm)	Air consumption (cm <sup>3</sup> /stroke)	Air pressure (MPa)	Stripping capacity $\phi$ (mm)	Stripping length (mm)
CST120	487	43	282.5	493	8,000	0.5~0.6	up to $\phi$ 30mm outer dia.	100



nile air tools

# CURL HOSE



**CURL HOSE.** It is covered with pure urethane tube utilizing the properties of the thermoplastic polyurethane resin.

It is an epoch-making air hose of outer diameter only  $\phi$  28mm.

**Utility** Cylinder apparatus, Coating spray gun, Industrial equipment, Food machinery, Medical equipment, Pneumatic tools General

Appearance	The outer diameter is $\phi$ 28mm (standard type) : therefore light and easy to handle.
Flexibility	It is flexible and light weight (1/3 of the rubber hose) : therefore grip operation is easy and makes your work simple.
Elasticity	It has high repulsion characteristics and can endure severe use.
Wear resistance	Wear resistance is 3-5 times that of rubber hose.
Chemical resistance	Except for hydrochloric acid, phosphoric acid, sulfuric acid, nitric acid, and caustic soda, methyl chloride, chlorine-Benz aldehyde non-human. It use the material for the best that can withstand most (30 days soaked)
Heat resistant	Up to 70°C
Cold resistant	It do not spoil the flexibility even in the state of -10°C
Pressure resistance	It will tolerate a 300,000 times or more expansion and contraction test in air pressure 0.7MPa.
Operability	The outside diameter of the curl is narrow and the both end of the hose are straight for a certain size, therefore it won't rent even handling them roughly.
Color tone	The color of the hose is mellow green to prevent eyestrain.

# CURL HOSE

## CURL HOSE

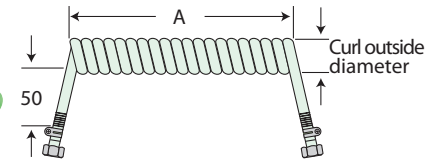

### CURL HOSE specification

Part number	Straight Portion A(mm)	Weight (g)	Curl outside diameter (φ mm)	Operating range (m)	Burst pressure (MPa)	Working pressure (MPa)	Inner Diameter× Outside Diameter (MPa)	Hose coupling	Carved seal No.
100	100	60	28	about 0.3	2.6	Up to 0.7	5×8	G1/4 Female thread	10
200	200	80		about 0.6					20
300	300	120		about 1.0					30
400	400	150		about 1.2					40
600	600	210		about 2.0					60
750	750	250		about 3.0					75

## CURL HOSE with straight hose

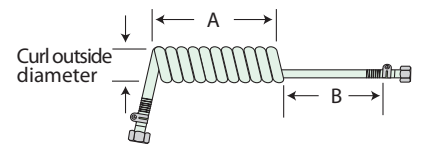
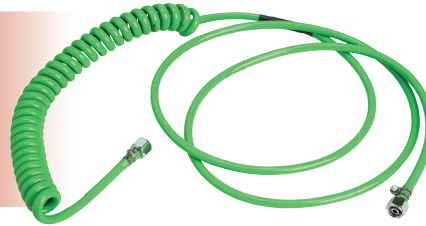

### CURL HOSE with straight hose specification

Part number	Straight Portion (mm)	Weight (g)	Curl outside diameter (φ mm)	Operating range (m)	Burst pressure (MPa)	Working pressure (MPa)	Inner Diameter× Outside Diameter (MPa)	Hose coupling	Carved seal No.
1800	Curl Div.(A)300	190	28	about 2.5	2.6	Up to 0.7	5×8	G1/4 Female thread	
	Straight Div.(B) 1,500								
3300	Curl Div.(A)300	240		about 4.0					
	Straight Div.(B) 3,000								

## Semi-blade hose

# Jumbo CURL HOSE

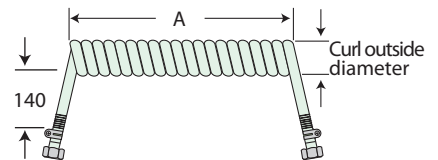

### Jumbo CURL HOSE specification

Part number	Straight Portion A(mm)	Weight (g)	Curl outside diameter (φ mm)	Operating range (m)	Burst pressure (MPa)	Working pressure (MPa)	Inner Diameter× Outside Diameter (MPa)	Hose coupling	Carved seal No.
G500	500	340	39	about 1.5	4.4	Up to 1.5	6.5×10	G1/4 Female thread	G5
G750	750	390		about 2.5					G7.5
G1000	1,000	500		about 4.0					G10
G1500	1,500	710		about 6.0					G15
G2000	2,000	920		about 8.0					G20

## Mini CURL HOSE

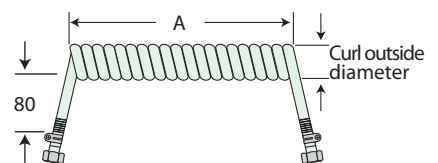
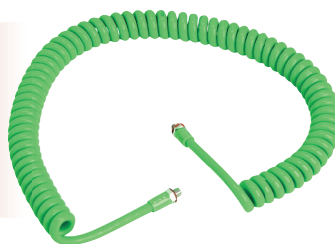

### Mini CURL HOSE specification

Part number	Straight Portion A(mm)	Weight (g)	Curl outside diameter (φ mm)	Operating range (m)	Burst pressure (MPa)	Working pressure (MPa)	Inner Diameter× Outside Diameter (MPa)	Hose coupling	Carved seal No.
M20	200	20	15	about 0.6	2.6	Up to 0.7	3×5	M5 Malethread	
M40	400	40		about 1.2					
M60	600	60		about 2.0					

# CURL HOSE

## Straight HOSE

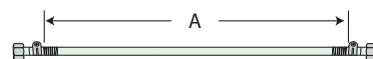
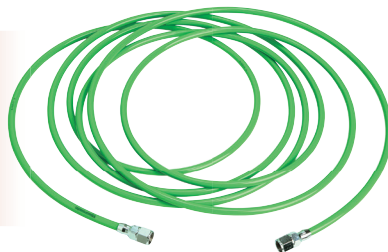

### Straight HOSE specification

Part number	Straight Portion A(mm)	Weight (g)	Curl outside diameter (φ mm)	Operating range (m)	Burst pressure (MPa)	Working pressure (MPa)	Inner Diameter× Outside Diameter (MPa)	Hose coupling	Carved seal No.
UH2	2,000	140			2.6	Up to 0.7	5×8	G1/4 Female thread	
UH3	3,000	180							
UH5	5,000	250							
UH7	7,000	340							
UH10	10,000	460							

## Thickly rolled Curl hose

## CHL type CURL HOSE

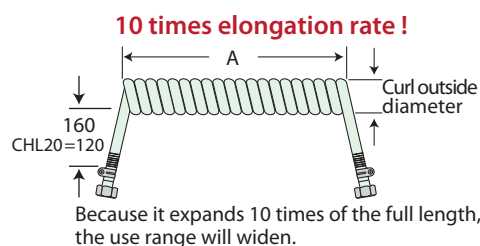

### CHL type CURL HOSE specification

Part number	Straight Portion A(mm)	Weight (g)	Curl outside diameter (φ mm)	Operating range (m)	Burst pressure (MPa)	Working pressure (MPa)	Inner Diameter× Outside Diameter (MPa)	Hose coupling	Carved seal No.
CHL20	200	200	56	about 2.0	2.6	Up to 0.7	5×8	G1/4 Female thread	L2
CHL30	300	270		about 3.0					L3
CHL40	400	340		about 4.0					L4
CHL50	500	400		about 5.0					L5
CHL60	600	450		about 6.0					L6

## Urethane air hose

## SE type CURL HOSE

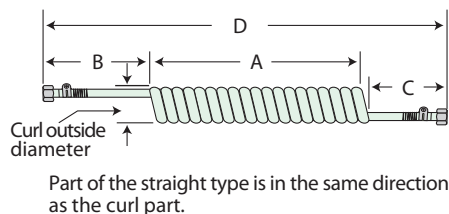

### SE type CURL HOSE specification

Part number	Straight Portion(mm)				Weight (g)	Curl outside diameter (φ mm)	Operating range (m)	Burst pressure (MPa)	Working pressure (MPa)	Inner Diameter× Outside Diameter (MPa)	Hose coupling	note	Carved seal No.
	A	B	C	D									
SE30	300	100	100	500	100	28	about 1.0	2.6	Up to 0.7	5×8	G1/4 Female thread	Both ends spring	E3
SE40	400	200	100	700	190		about 1.5						E4
SE50	500	230	100	830	220		about 2.0						E5
SE60	600	230	100	930	250		about 2.5						E6
SE70	700	230	100	1,030	280		about 3.0						E7
SE80	800	230	100	1,130	310		about 3.5						E8

## Urethane air hose

## GS type CURL HOSE

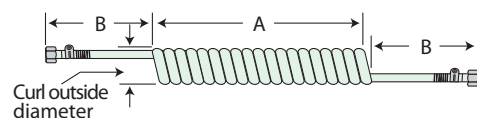

### GS type CURL HOSE specification

Part number	Straight Portion(mm)		Weight (g)	Curl outside diameter (φ mm)	Operating range (m)	Working pressure (MPa)	Inner Diameter× Outside Diameter (MPa)	Hose coupling	Carved seal No.
	A	B							
GS650	650	160	360	39	about 2.0	Up to 0.7	6.5×10	G1/4 Female thread	S65
GS750	750	160	410		about 2.5				S75
GS850	850	160	450		about 3.0				S85
GS950	950	160	510		about 3.5				S95



**MERRY**

**MUROMO TO**  
"MERRY" BRAND  
HAND TOOLS



**SIDE CUTTING PLIERS  
NIPPERS  
NIPPERS FOR PIANO WIRE  
LONG NOSE SIDE CUTTING PLIERS & PLIERS  
NIPPERS FOR CUTTING PLASTICS 160S SERIES  
NIPPERS FOR CUTTING PLASTICS HOT SELLER  
END CUTTING PLASTICS NIPPERS /  
R-CUT NIPPERS FOR CUTTING PLASTICS  
NIPPERS FOR CUTTING PLASTICS OTHERS  
HEAT NIPPERS FOR CUTTING PLASTICS  
SERIES THING  
CLIP PLIERS / SNAP RING PLIERS / DUCT CUTTERS  
PLASTIC PIPE CUTTERS  
DUCT AND MOULD CUTTERS / MERRY CUTTERS  
STRIPPERS  
OTHERS**





MERRY

# SIDE CUTTING PLIERS



# SIDE CUTTING PLIERS

## 1050 <sup>JIS</sup>

Side cutting pliers

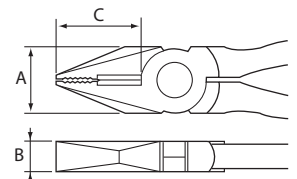
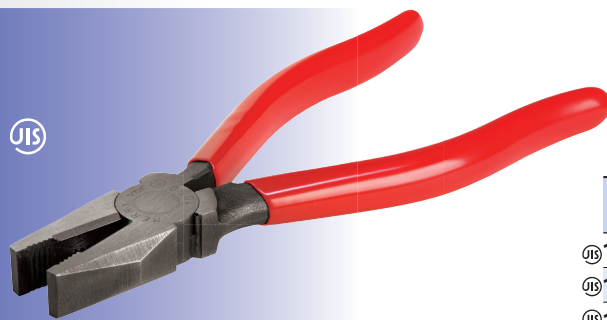

Model	Size (mm)	Dimensions(mm)			Weight (g)	Cutting capacity (φmm)	
		A	B	C		Steel wire	Copper wire
⑪ 1050-150	150	22.0	12.5	26.0	200	2.0	3.0
⑪ 1050-175	175	23.5	13.5	30.5	275	2.6	3.5
⑪ 1050-200	200	26.5	14.5	32.0	375	3.2	4.0

## 1050H <sup>JIS</sup>

Side cutting pliers

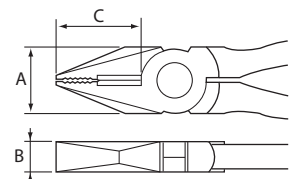

Model	Size (mm)	Dimensions(mm)			Weight (g)	Cutting capacity (φmm)	
		A	B	C		Steel wire	Copper wire
⑪ 1050H-150	150	22.0	12.5	26.0	210	2.0	3.0
⑪ 1050H-175	175	23.5	13.5	30.5	285	2.6	3.5
⑪ 1050H-200	200	26.5	14.5	32.0	385	3.2	4.0

## 2050

High leverage side cutting pliers

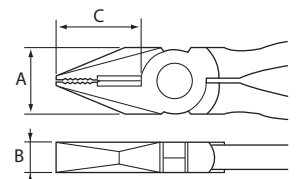

Model	Size (mm)	Dimensions(mm)			Weight (g)	Cutting capacity (φmm)	
		A	B	C		Steel wire	Copper wire
2050-185	185	25.5	13.5	33.0	290	3.2	4.0
2050-225	225	27.0	14.5	35.0	370	3.6	4.5

## 2060 2060N

High leverage side cutting pliers  
◀with crimping die▶

Stripping hole  
Crimping

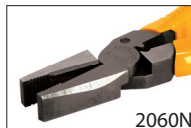
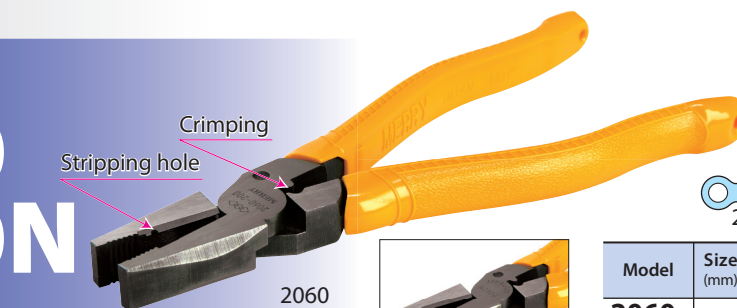

2.0sq

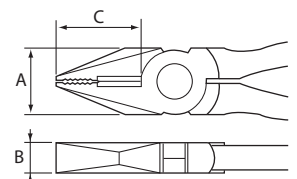

Model	Size (mm)	Dimensions(mm)			Weight (g)	Cutting capacity (φmm)	
		A	B	C		Steel wire	Copper wire
2060	200	25.5	13.5	37.0	293	3.2	4.0
2060N	200	25.5	13.5	37.0	300	3.2	4.0

## 2060U

VA cutting pliers  
◀with crimping die▶

Crimping

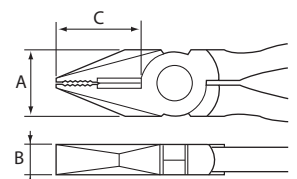
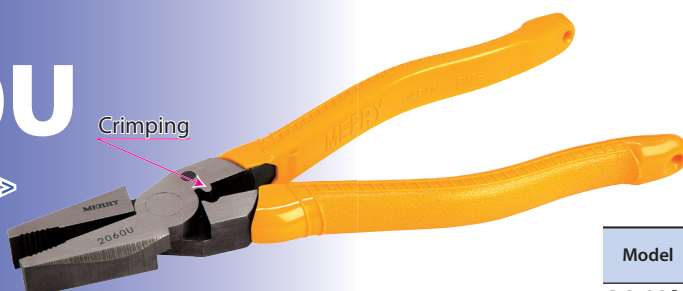

Model	Size (mm)	Dimensions(mm)			Weight (g)	Cutting capacity (φmm)	
		A	B	C		Copper wire	VVF wire
2060U	200	25.5	13.5	37.0	285	4.0	φ2.0×3.0

# SIDE CUTTING PLIERS

## 2080 2080N

Slim type side cutting pliers

Stripping hole



2080-185

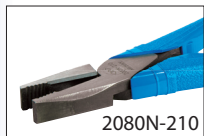

2080N-210

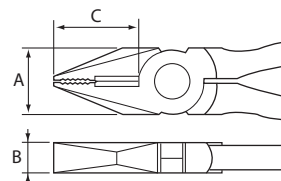

Model	Size (mm)	Dimensions(mm)			Weight (g)	Cutting capacity (φmm)	
		A	B	C		Steel wire	Copper wire
<b>2080-185</b>	185	20.0	12.0	33.0	214	3.2	4.0
<b>2080-210</b>	210	23.0	12.5	37.0	274	3.6	4.5
<b>2080N-185</b>	185	20.0	12.0	33.0	213	3.2	4.0
<b>2080N-210</b>	210	23.0	12.5	37.0	272	3.6	4.5

## 6050

Side cutting pliers  
◀with crimping die▶

Crimping

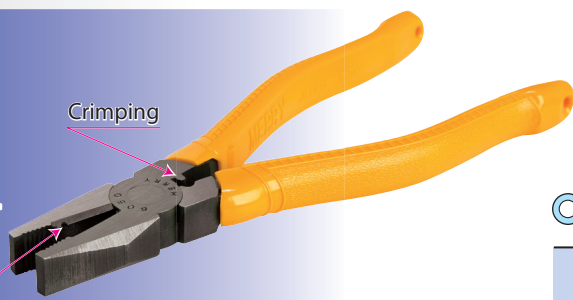

Stripping hole

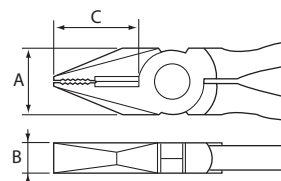

Model	Size (mm)	Dimensions(mm)			Weight (g)	Cutting capacity (φmm)	
		A	B	C		Steel wire	Copper wire
<b>6050</b>	185	24.0	14.0	33.0	295	2.6	3.5

## XP200

Side cutting pliers  
for electrical work



Elastomer cover

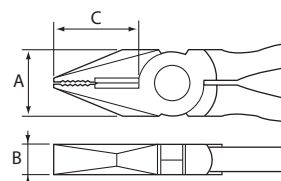

Model	Size (mm)	Dimensions(mm)			Weight (g)	Cutting capacity (φmm)	
		A	B	C		Steel wire	Copper wire
<b>XP200</b>	200	27.5	13.5	33.0	360	3.6	4.5

## 8050

Center cutting pliers



8050-185



8050-210

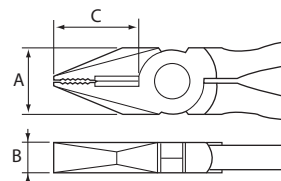

Model	Size (mm)	Dimensions(mm)			Weight (g)	Cutting capacity (φmm)		
		A	B	C		Steel wire	Copper wire	VVF
<b>8050-185</b>	185	23.0	11.7	30.5	235	3.2	4.0	1.6×2
<b>8050-210</b>	210	24.5	13.5	35.5	300	3.6	4.5	2.0×3

## 2070

High leverage  
side cutting pliers

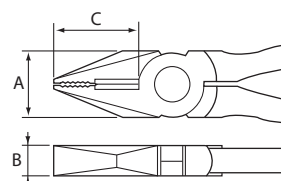

Model	Size (mm)	Dimensions(mm)			Weight (g)	Cutting capacity (φmm)	
		A	B	C		Steel wire	Copper wire
<b>2070</b>	225	27.0	12.4	38.5	360	4.0	5.0



MERRY

# NIPPERS

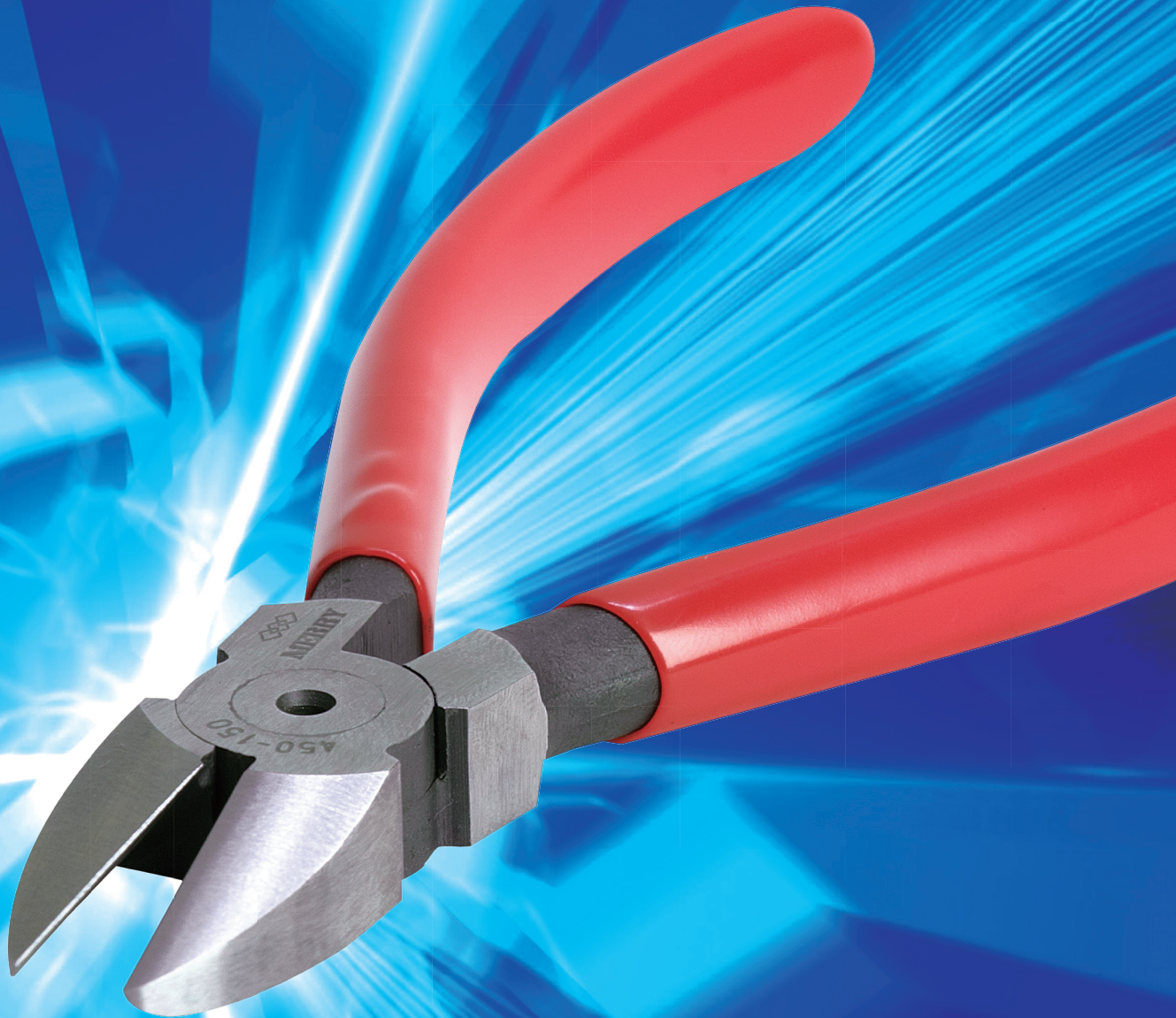

# NIPPERS

Blade shape

Standard

for cutting hard wire

Semi-flush

for cutting medium wire

Full-flush

for cutting soft wire only or plastic, gate and sprue

## 205 JIS

Diagonal cutting nippers

Standard

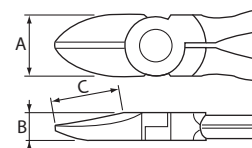
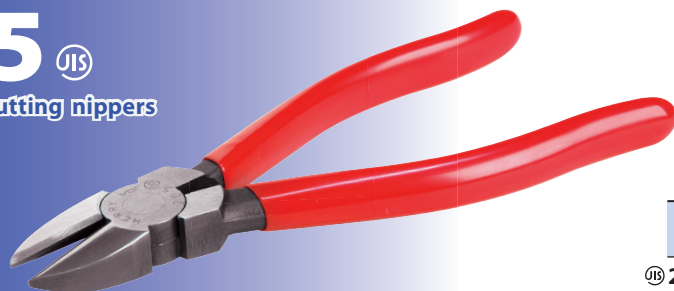

Model	Size (mm)	Dimensions(mm)			Weight (g)	Cutting capacity (φmm)	
		A	B	C		Steel wire	Copper wire
⑧ 205-150	150	22.0	12.5	22.5	185	2.0	2.6
⑧ 205-175	175	24.5	13.0	26.5	260	2.0	3.0
205-200	200	26.5	14.0	30.0	330	2.6	3.5

## 205H JIS

Diagonal cutting nippers

Standard

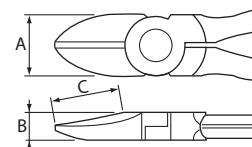
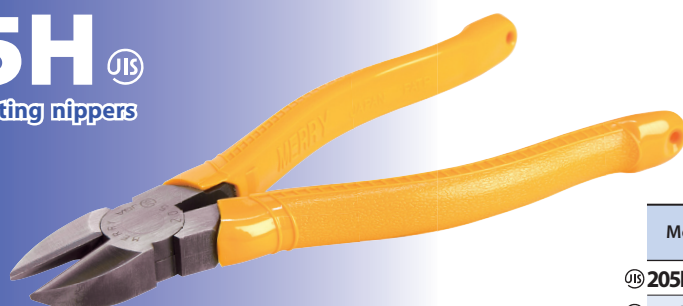

Model	Size (mm)	Dimensions(mm)			Weight (g)	Cutting capacity (φmm)	
		A	B	C		Steel wire	Copper wire
⑧ 205H-150	150	22.0	12.5	22.5	195	2.0	2.6
⑧ 205H-175	175	24.5	13.0	26.5	270	2.0	3.0
205H-200	200	26.5	14.0	30.0	345	2.6	3.5

## 206S

Flush diagonal nippers

Spring Loaded

Full-flush

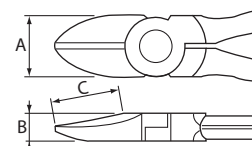
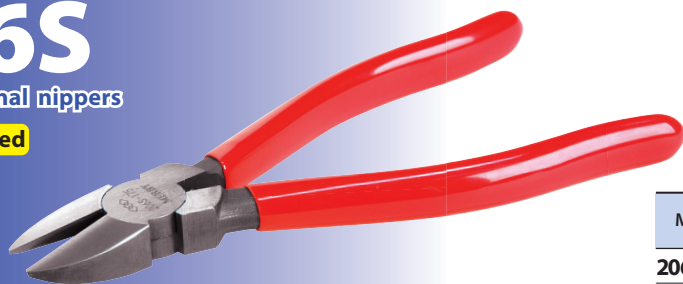

Model	Size (mm)	Dimensions(mm)			Weight (g)	Cutting capacity (φmm)	
		A	B	C		Steel wire	Copper wire
206S-150	150	22.5	12.5	22.0	185	2.0	2.6
206S-175	175	24.5	13.0	26.5	260	2.0	3.0
206S-200	200	26.0	14.0	29.0	330	2.6	3.5

## 207

Diagonal cutting nippers  
<with crimping die>

Standard

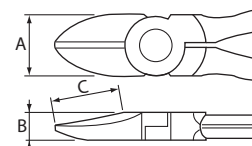

Model	Size (mm)	Dimensions(mm)			Weight (g)	Cutting capacity (φmm)	
		A	B	C		Steel wire	Copper wire
207	225	26.0	12.2	27.0	347	3.0	4.0

# NIPPERS

Blade shape **Standard**



for cutting hard wire

**Semi-flush**



for cutting medium wire

**Full-flush**



for cutting soft wire only or plastic, gate and sprue

## 99W

VA cutting nippers

**Full-flush**

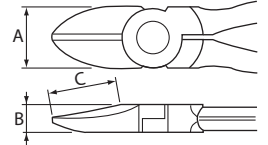
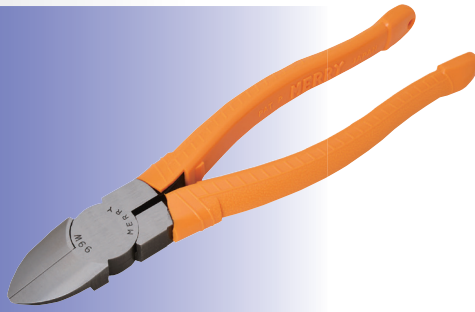

Model	Size (mm)	Dimensions(mm)			Weight (g)	Cutting capacity (φmm)	
		A	B	C		VVF wire	
<b>99W-150</b>	150	22.0	12.5	21.5	220	φ2.0×3.0	
<b>99W-175</b>	175	24.0	12.5	25.0	275	φ2.0×3.0	
<b>99W-200</b>	200	26.5	14.0	29.0	355	φ2.6×3.0	

## 550

Cutting nippers

**Semi-flush**

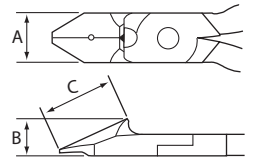
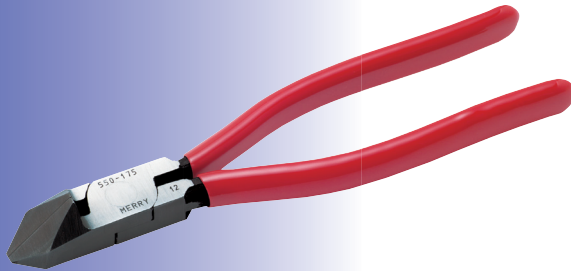

Model	Size (mm)	Dimensions(mm)			Weight (g)	Cutting capacity (φmm)	
		A	B	C		Steel wire	Copper wire
<b>550-150</b>	150	15.0	15.0	25.0	140	1.6	2.0
<b>550-175</b>	175	18.0	18.5	28.0	186	2.0	3.0

## 405

End cutting nippers

**Spring Loaded**

**Standard**

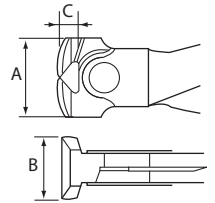

Model	Size (mm)	Dimensions(mm)			Weight (g)	Cutting capacity (φmm)	
		A	B	C		Steel wire	Copper wire
<b>405-7</b>	175	30.5	24.5	7.5	245	2.0	3.0
<b>405-8</b>	200	36.5	30.5	7.5	300	2.4	3.2
<b>405-9</b>	230	37.0	30.0	7.5	324	2.6	3.5

## 55S

Electronic nippers

**Spring Loaded**

**Semi-flush**

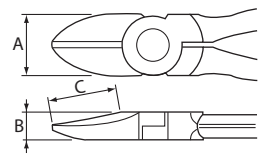
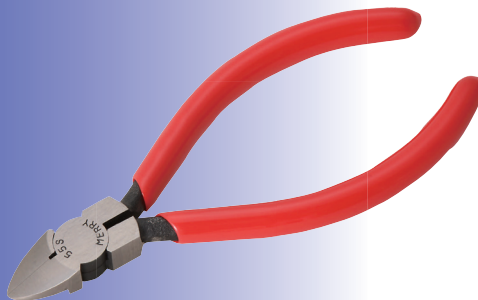

Model	Size (mm)	Dimensions(mm)			Weight (g)	Cutting capacity (φmm)	
		A	B	C		Steel wire	Copper wire
<b>55S-120</b>	120	13.0	8.5	14.5	70	0.8	1.2
<b>55S-150</b>	150	17.5	10.5	21.0	130	1.5	2.6

## 55S-PM

Electronic nippers  
◀wire holding type▶

**Spring Loaded**

**Semi-flush**

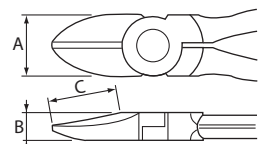
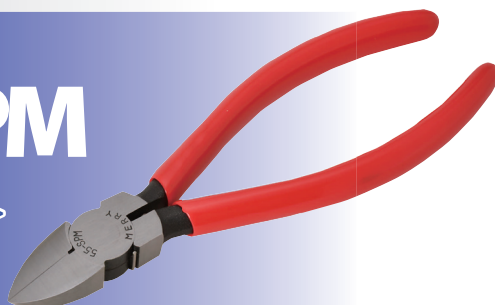

Model	Size (mm)	Dimensions(mm)			Weight (g)	Cutting capacity (φmm)	
		A	B	C		Steel wire	Copper wire
<b>55S-PM-120</b>	120	13.0	8.0	14.5	70	0.8	1.2
<b>55S-PM-150</b>	150	17.0	10.5	20.5	130	1.5	2.6

# NIPPERS

Blade shape **Standard**  for cutting hard wire

**Semi-flush**  for cutting medium wire

**Full-flush**  for cutting soft wire only or plastic, gate and sprue

## 450

Diagonal cutting nippers

Spring Loaded

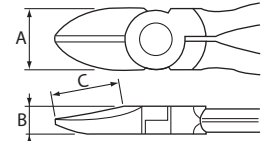
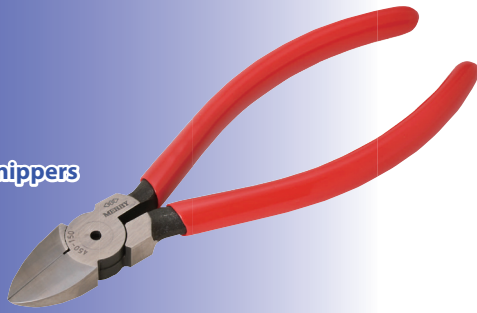

Model	Size (mm)	Dimensions(mm)			Weight (g)	Cutting capacity (φmm)	
		A	B	C		Steel wire	Copper wire
<b>450-125</b>	125	12.5	8.0	14.0	70	0.8	1.2
<b>450-150</b>	150	17.0	10.0	20.5	130	1.5	2.6

## 305

Wire nippers  
<for hard wire>

Spring Loaded

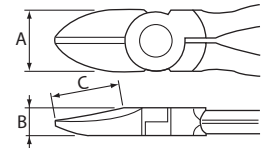

Model	Size (mm)	Dimensions(mm)			Weight (g)	Cutting capacity (φmm)	
		A	B	C		Steel wire	Copper wire
<b>305-7</b>	175	24.0	12.5	20.0	195	2.6	3.5
<b>305-8</b>	200	26.5	12.5	23.0	245	3.2	4.0

## WA1000

Compound cutting nippers

Spring Loaded

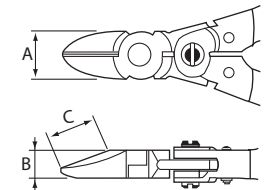
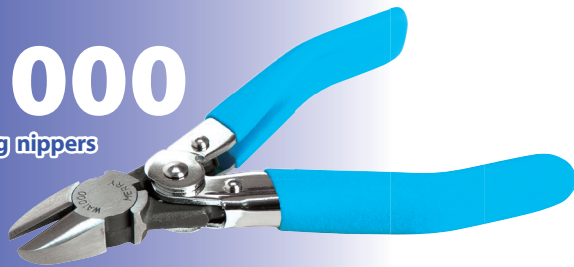

Model	Size (mm)	Dimensions(mm)			Weight (g)	Cutting capacity (φmm)	
		A	B	C		Steel wire	Copper wire
<b>WA1000</b>	160	19.0	11.0	17.0	160	2.0	2.6

## XN200

Diagonal cutting nippers  
for electrical work

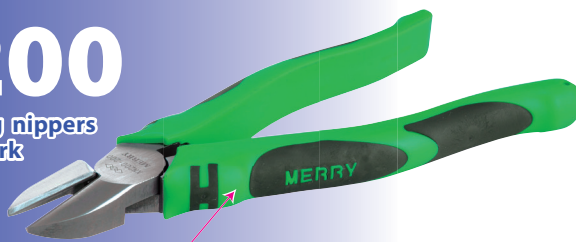

Elastomer cover

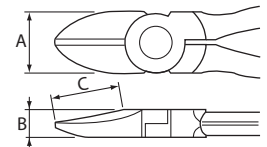

Model	Size (mm)	Dimensions(mm)			Weight (g)	Cutting capacity (φmm)	
		A	B	C		Steel wire	Copper wire
<b>XN200</b>	200	26.5	13.5	28.0	330	2.6	3.5

## 205T

Diagonal cutting nippers  
<Luminous cover>

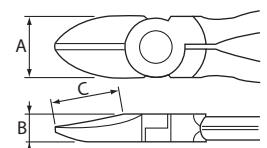

Model	Size (mm)	Dimensions(mm)			Weight (g)	Cutting capacity (φmm)	
		A	B	C		Steel wire	Copper wire
<b>205T-150</b>	150	22.0	12.5	22.5	191	2.0	2.6
<b>205T-175</b>	175	24.5	13.0	26.5	243	2.0	3.0
<b>205T-200</b>	200	26.5	14.0	30.0	324	2.6	3.5



MERRY

# NIPPERS FOR PIANO WIRE





# NIPPERS FOR PIANO WIRE

Blade shape **Standard**  for cutting hard wire

**Semi-flush**  for cutting medium wire

**Full-flush**  for cutting soft wire only or plastic, gate and sprue

## CT55

Electro nippers  
<carbide tipped>

Spring Loaded

Semi-flush 

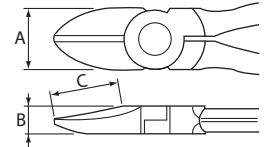
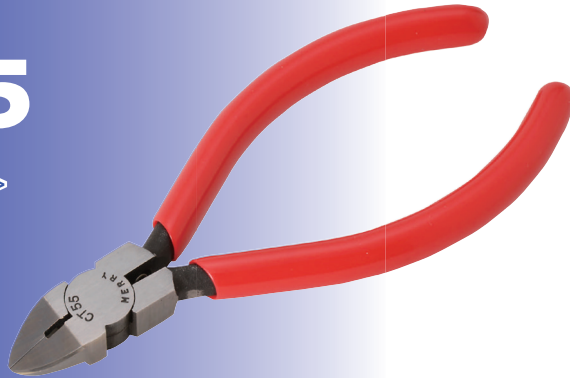

Model	Size (mm)	Dimensions(mm)			Weight (g)	Cutting capacity (φmm)	
		A	B	C		Piano wire	
CT55-120	120	12.0	8.0	8.0	70	0.5	
CT55-150	150	17.0	10.0	16.0	135	0.5	

## CT305

Diagonal cutting nippers  
<carbide tipped>

Spring Loaded

Standard 

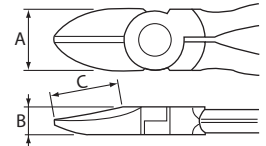

Model	Size (mm)	Dimensions(mm)			Weight (g)	Cutting capacity (φmm)	
		A	B	C		Piano wire	
CT305-7	175	24.0	12.0	16.0	195	1.0	
CT305-8	200	26.0	12.0	16.0	245	1.2	

## P56

Steel wire cutting nippers

Spring Loaded

Semi-flush 

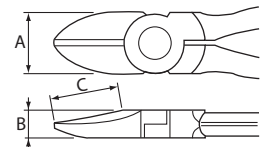
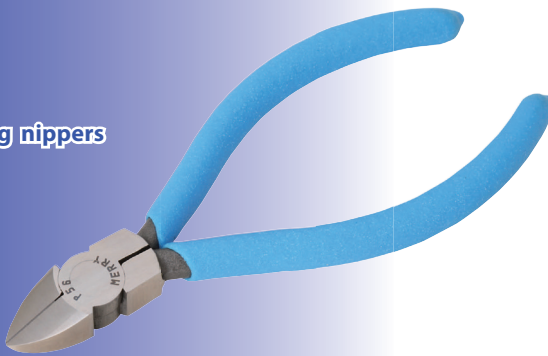

Model	Size (mm)	Dimensions(mm)			Weight (g)	Cutting capacity (φmm)	
		A	B	C		Piano wire	
P56	120	12.0	8.5	12.0	70	0.5	

## 203

High leverage  
steel wire cutting nippers

Spring Loaded

Standard 

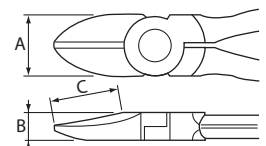

Model	Size (mm)	Dimensions(mm)			Weight (g)	Cutting capacity (φmm)	
		A	B	C		Steel wire(Welding wire)	
203	175	24.0	12.5	24.0	261	1.6	



MERRY

# LONG NOSE SIDE CUTTING PLIERS & PLIERS



# LONG NOSE SIDE CUTTING PLIERS & PLIERS

## 105 JIS

Long nose side cutting pliers

Spring Loaded

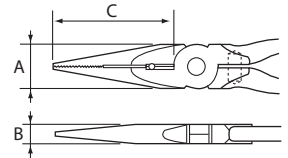
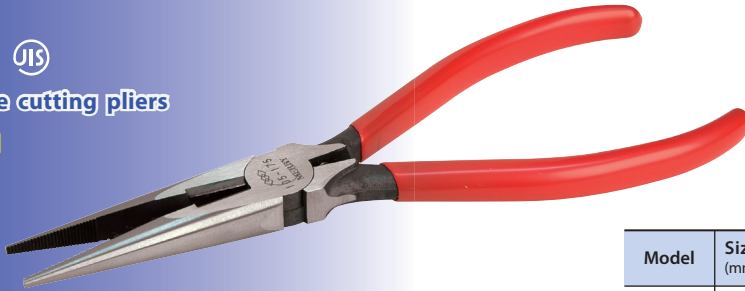

Model	Size (mm)	Dimensions(mm)			Weight (g)	Cutting capacity (φmm)	
		A	B	C		Steel wire	Copper wire
105-150	150	17.0	10.5	50.0	115	1.5	2.6
105-175	175	19.0	10.5	59.0	150	2.0	3.0

## 105H JIS

Long nose side cutting pliers

Spring Loaded

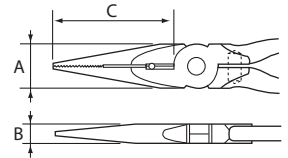

Model	Size (mm)	Dimensions(mm)			Weight (g)	Cutting capacity (φmm)	
		A	B	C		Steel wire	Copper wire
105H-150	150	17.0	10.5	50.0	130	1.5	2.6
105H-175	175	19.0	10.5	59.0	165	2.0	3.0

## 150

Long nose side cutting pliers  
◀slim type▶

Spring Loaded

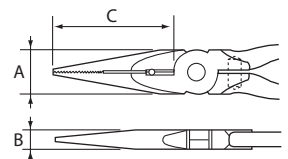
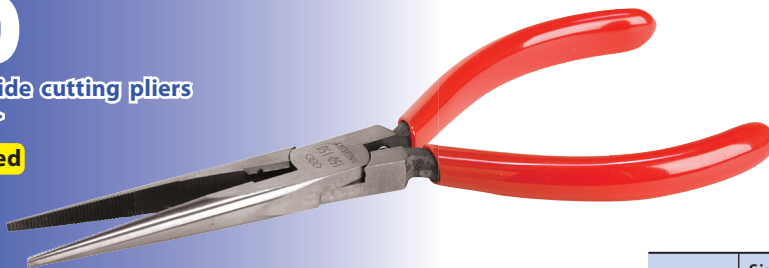

Model	Size (mm)	Dimensions(mm)			Weight (g)	Cutting capacity (φmm)	
		A	B	C		Steel wire	Copper wire
150	150	12.0	7.5	57.5	65	1.2	2.0

## 105F

Flat nose pliers

Spring Loaded

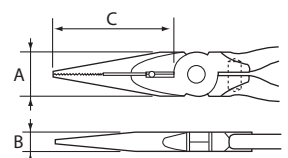
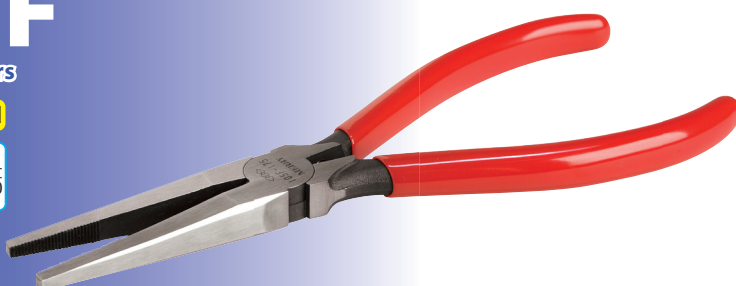
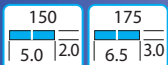

Model	Size (mm)	Dimensions(mm)			Weight (g)
		A	B	C	
105F-150	150	17.0	10.0	50.0	110
105F-175	175	19.5	11.5	59.0	160

# LONG NOSE SIDE CUTTING PLIERS & PLIERS

## 2500

Duck-bill pliers

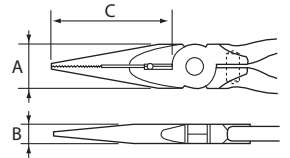

Model	Size (mm)	Dimensions(mm)			Weight (g)
		A	B	C	
<b>2500</b>	200	15.5	11.5	38.0	180

## 2500R

Long reach needle nose pliers

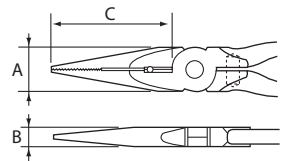

Model	Size (mm)	Dimensions(mm)			Weight (g)
		A	B	C	
<b>2500R</b>	200	15.5	11.5	39.0	180

## 2500T

Nail pliers for tire repair  
 <special hand tool for removing nails on tires.>

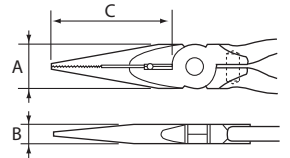

Model	Size (mm)	Dimensions(mm)			Weight (g)
		A	B	C	
<b>2500T</b>	200	15.5	11.0	38.0	175

## Y75

Heavy-duty semi-Long nose pliers

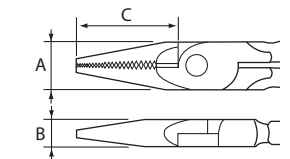
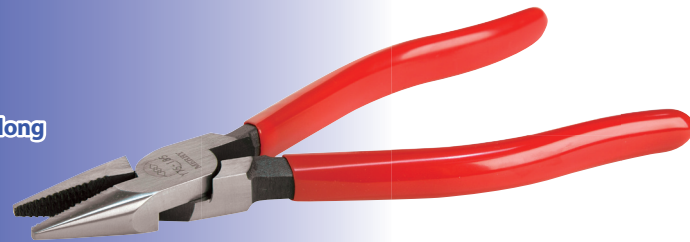

Model	Size (mm)	Dimensions(mm)			Weight (g)
		A	B	C	
<b>Y75-185</b>	185	20.0	12.5	32.0	260
<b>Y75-225</b>	225	24.0	14.5	35.0	370

## ZA185

Screw pliers

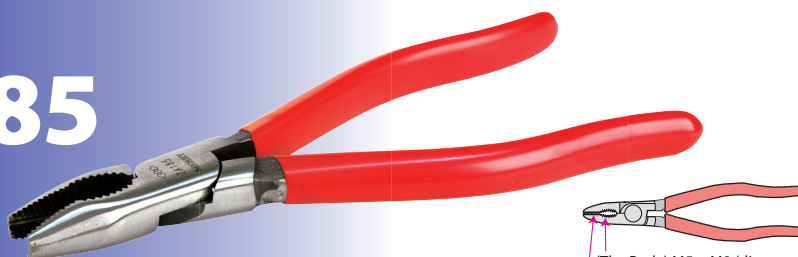

(The Body) M5~M8 (diameter of the head is less than  $\phi$  14)  
 (The Tip) M2~M6 (diameter of the head is less than  $\phi$  10)

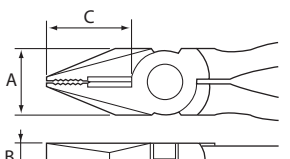

Model	Size (mm)	Dimensions(mm)			Weight (g)
		A	B	C	
<b>ZA185</b>	185	21.0	13.0	31.0	250



MERRY

# NIPPERS FOR CUTTING PLASTICS 160S SERIES



# NIPPERS FOR CUTTING PLASTICS 160S SERIES

Section of blade **Round type** **Flat type** **Angle type**

## 160S

High plastic nippers  
<with adjustable stopper>

**Spring Loaded**

**Round type**

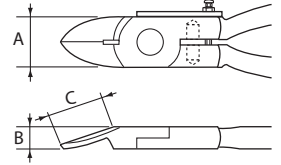
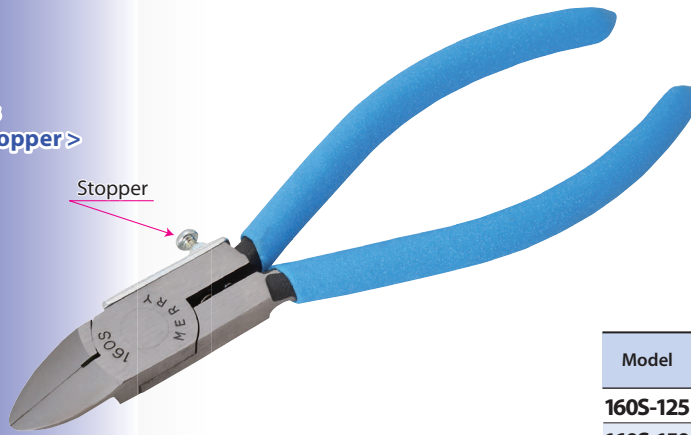

Model	Size (mm)	Dimensions (mm)			Weight (g)	Cutting capacity (φmm) Plastics
		A	B	C		
160S-125	125	14.0	7.5	16.0	75	3.0
160S-150	150	16.0	8.0	17.0	110	5.0

## 160SF

High plastic nippers  
<with adjustable stopper>

**Spring Loaded**

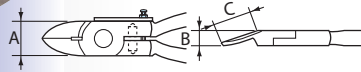
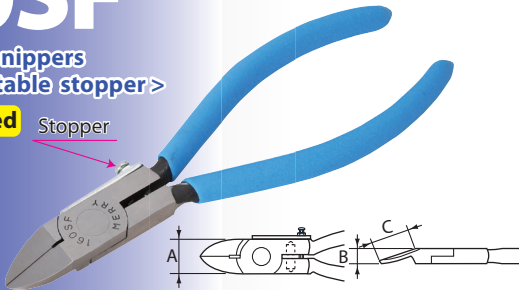

Model	Size (mm)	Dimensions (mm)			Weight (g)	Cutting capacity (φmm) Plastics
		A	B	C		
160SF-125	125	14.0	7.5	16.0	75	3.0
160SF-150	150	16.0	8.0	17.0	110	5.0

**Flat type**

## 160GT

High plastic nippers  
<Leaf spring>

**Spring Loaded**

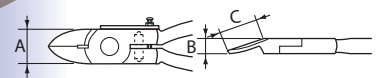
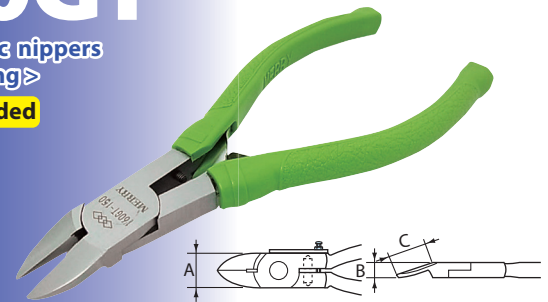

Model	Size (mm)	Dimensions (mm)			Weight (g)	Cutting capacity (φmm) Plastics
		A	B	C		
160GT	150	16.0	8.0	17.0	117	5.0

**Round type**

## 160SA

High plastic nippers  
<with adjustable stopper>

**Spring Loaded**

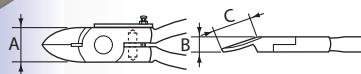
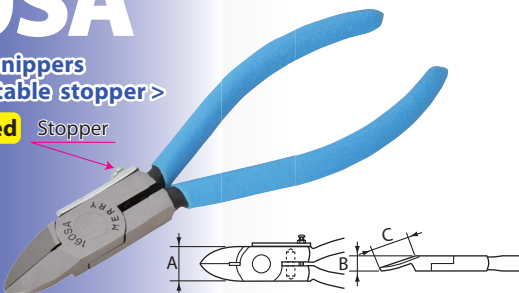

Model	Size (mm)	Dimensions (mm)			Weight (g)	Cutting capacity (φmm) Plastics
		A	B	C		
160SA-125	125	14.0	7.5	16.0	75	3.0
160SA-150	150	16.0	8.0	17.0	110	5.0

**Angle type**

## X160

High plastic nippers  
<with adjustable stopper>

**Spring Loaded**

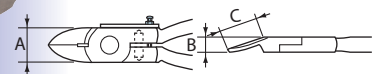
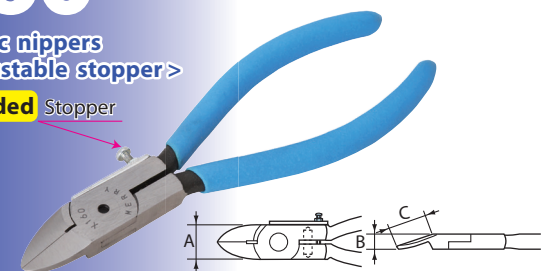

Model	Size (mm)	Dimensions (mm)			Weight (g)	Cutting capacity (φmm) Plastics
		A	B	C		
X160-125	125	14.0	7.5	16.0	72	3.0
X160-150	150	16.0	8.0	17.0	114	5.0

**Round type**

## 160FW

High plastic nippers  
<with adjustable stopper>

**Spring Loaded**

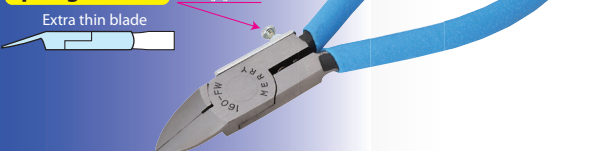

Model	Size (mm)	Dimensions (mm)			Weight (g)	Cutting capacity (φmm) Plastics
		A	B	C		
160FW-125	125	14.0	7.5	16.0	75	2.0
160FW-150	150	16.0	8.0	17.0	110	4.0

**Round type**

## CT160F

Plastic nippers  
<carbide tipped>

**Spring Loaded**

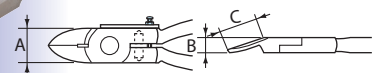
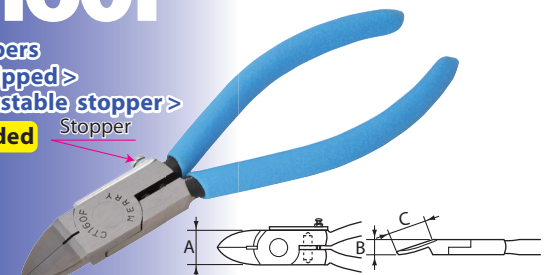

Model	Size (mm)	Dimensions (mm)			Weight (g)	Cutting capacity (φmm) Plastics
		A	B	C		
CT160F-125	125	14.0	7.0	14.0	75	3.0
CT160F-150	150	16.0	8.0	15.0	110	5.0

**Flat type**



MERRY

# NIPPERS FOR CUTTING PLASTICS HOT SELLER



# NIPPERS FOR CUTTING PLASTICS

## HOT SELLER

Section of blade

Round type

Flat type

Angle type

### 170S

Angled plastic nippers

Spring Loaded

Flat type

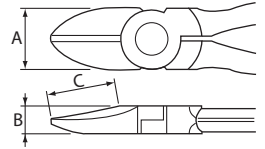
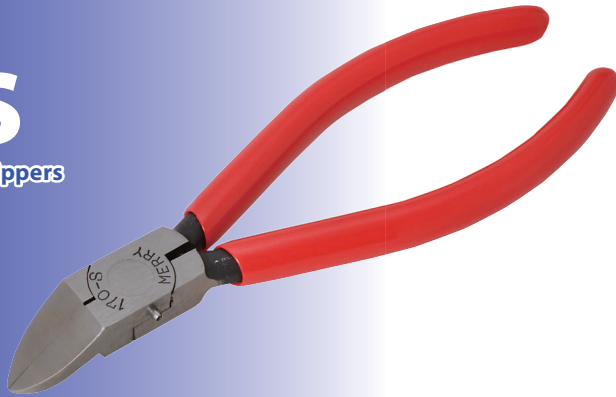
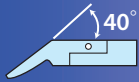

Model	Size (mm)	Dimensions (mm)			Weight (g)	Cutting capacity (φmm)
		A	B	C		Plastics
<b>170S</b>	150	15.0	10.0	22.0	120	5.0

### 99

Heavy-duty plastic nippers

Spring Loaded

Round type

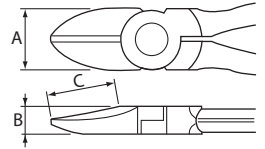
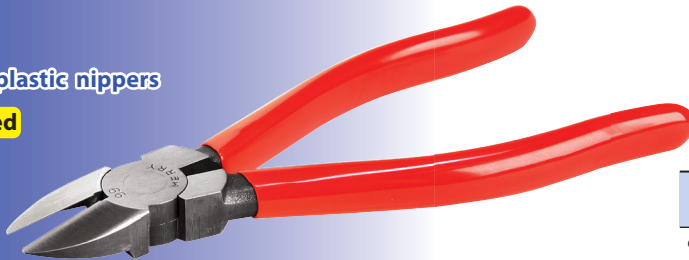

Model	Size (mm)	Dimensions (mm)			Weight (g)	Cutting capacity (φmm)
		A	B	C		Plastics
<b>99-150</b>	150	22.0	12.5	18.0	185	8.0
<b>99-175</b>	175	24.0	12.5	23.0	235	9.0
<b>99-200</b>	200	26.0	13.5	27.0	310	10.0

### 99S

Heavy-duty plastic nippers  
<with adjustable stopper>

Spring Loaded

Stopper

Round type

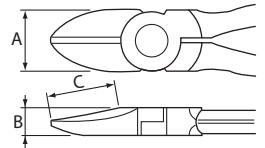
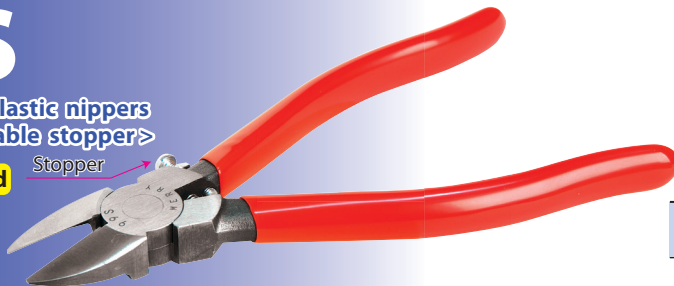

Model	Size (mm)	Dimensions (mm)			Weight (g)	Cutting capacity (φmm)
		A	B	C		Plastics
<b>99S-150</b>	150	22.0	12.5	18.0	185	8.0
<b>99S-175</b>	175	24.0	12.5	23.0	240	9.0
<b>99S-200</b>	200	26.0	13.5	27.0	315	10.0

### 99SF

Heavy-duty plastic nippers  
<with adjustable stopper>

Spring Loaded

Stopper

Flat type

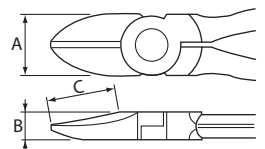

Model	Size (mm)	Dimensions (mm)			Weight (g)	Cutting capacity (φmm)
		A	B	C		Plastics
<b>99SF-150</b>	150	22.0	12.5	20.0	185	8.0
<b>99SF-175</b>	175	24.0	12.5	24.0	240	9.0
<b>99SF-200</b>	200	25.5	13.5	28.0	315	10.0



# NIPPERS FOR CUTTING PLASTICS

## HOT SELLER

Section of blade

Round type

Flat type

Angle type

### 66S

Plastic nippers

Spring Loaded

Round type

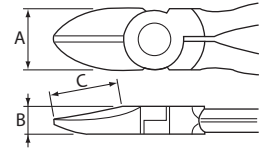
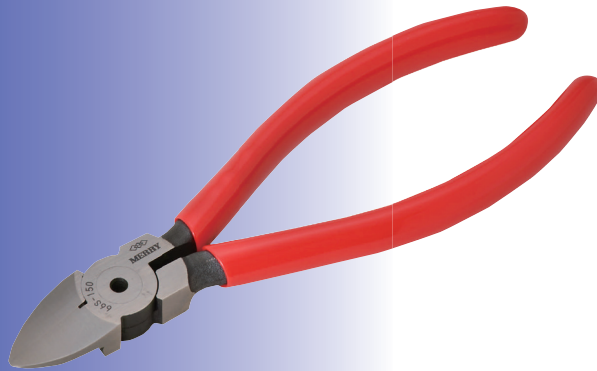

Model	Size (mm)	Dimensions(mm)			Weight (g)	Cutting capacity (φmm)
		A	B	C		Plastics
<b>66S</b>	150	17.0	10.0	18.0	130	5.0

### 68S

Narrow nose plastic nippers

Spring Loaded

Round type

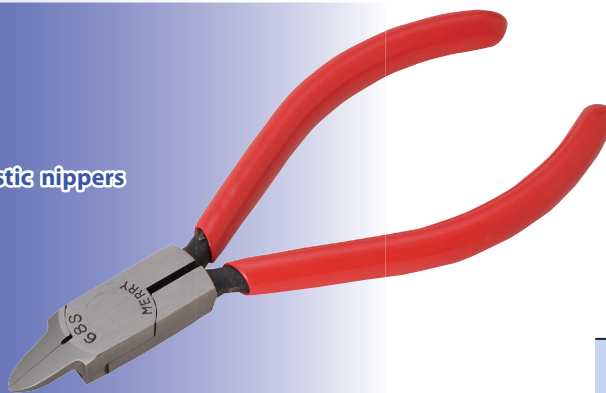

For cutting in narrow spaces.

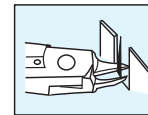

Model	Size (mm)	Dimensions(mm)			Weight (g)	Cutting capacity (φmm)
		A	B	C		Plastics
<b>68S</b>	125	12.5	8.0	12.0	70	2.0

### M11

Miniature plastic cutting nippers

Spring Loaded

Round type

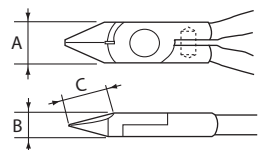
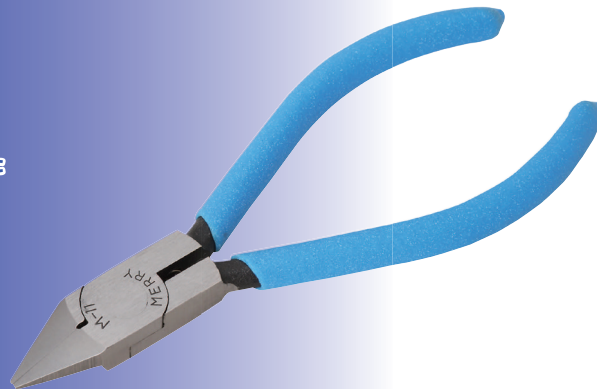

Model	Size (mm)	Dimensions(mm)			Weight (g)	Cutting capacity (φmm)
		A	B	C		Plastics
<b>M11</b>	125	14.0	8.0	15.0	75	3.0

### M12

Miniature plastic cutting nippers

Spring Loaded

Round type

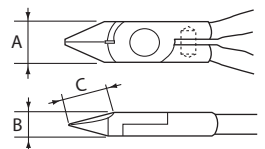
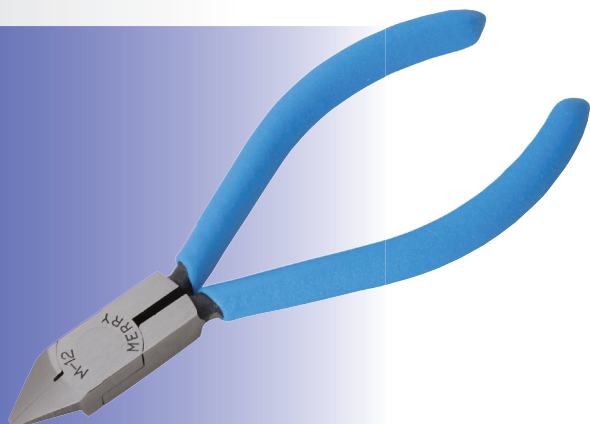

Model	Size (mm)	Dimensions(mm)			Weight (g)	Cutting capacity (φmm)
		A	B	C		Plastics
<b>M12</b>	125	12.5	8.5	12.0	75	3.0



MERRY

# END CUTTING PLASTICS NIPPERS

# R-CUT NIPPERS FOR CUTTING PLASTICS



# END CUTTING PLASTICS NIPPERS

## R-CUT NIPPERS FOR CUTTING PLASTICS

### 23EF

End cutting plastic nippers

Spring Loaded

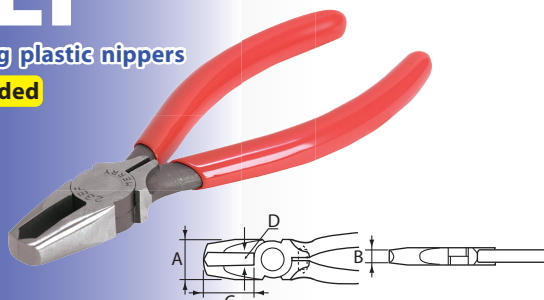

Model	Size (mm)	Dimensions (mm)				Weight (g)	Cutting capacity (φmm)	
		A	B	C	D		Plastics	
23EF	130	17.0	7.0	20.0	6.0	105	Plastics	3.0

### 2000EF

End cutting plastic nippers

Spring Loaded

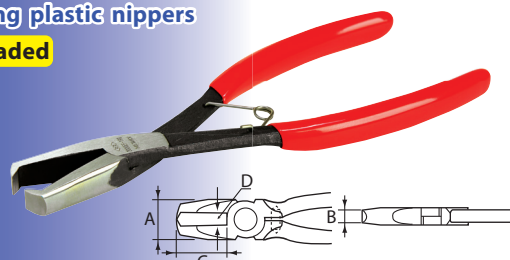

Model	Size (mm)	Dimensions (mm)				Weight (g)	Cutting capacity (φmm)	
		A	B	C	D		Plastics	
2000EF	190	18.0	8.0	35.0	20~90	175	Plastics	3.0

### 24EF

End cutting plastic nippers

Spring Loaded

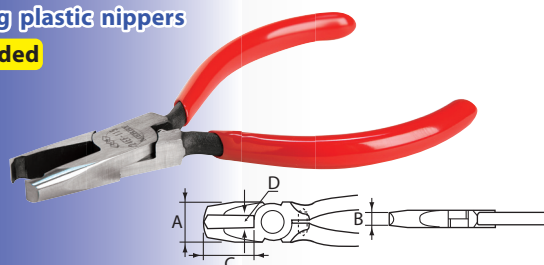

Model	Size (mm)	Dimensions (mm)				Weight (g)	Cutting capacity (φmm)	
		A	B	C	D		Plastics	
24EF	115	13.0	5.5	20.0	3.0	65	Plastics	3.0

### PG20

Pin gate plastic nippers  
<with adjustable stopper>

Spring Loaded

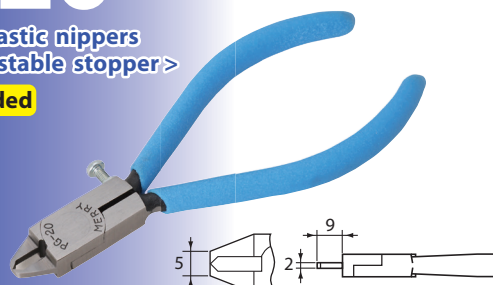

Model	Size (mm)	Weight (g)	Cutting capacity (φmm)	
			Plastics	
PG20	125	70	Plastics	1.0

### 25EF

End cutting plastic nippers

Spring Loaded

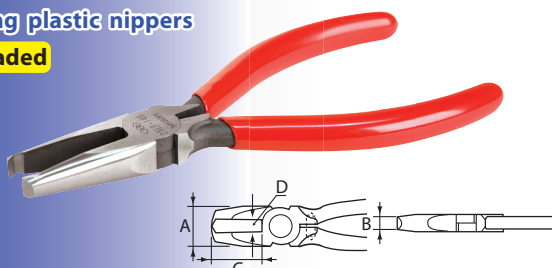

Model	Size (mm)	Dimensions (mm)				Weight (g)	Cutting capacity (φmm)	
		A	B	C	D		Plastics	
25EF	145	17.0	5.5	31.0	4.0	110	Plastics	3.0

### CX25R

R-cut plastic nippers  
<with adjustable stopper>

Spring Loaded

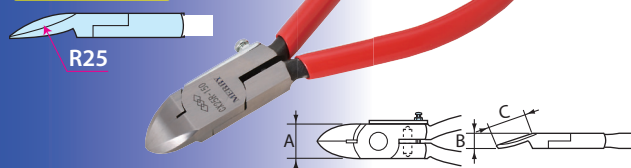

Model	Size (mm)	Dimensions (mm)			Weight (g)	Cutting capacity (φmm)	
		A	B	C		Plastics	
CX25R	150	16.0	8.5	13.0	110	Plastics	5.0

### 26EF

End cutting plastic nippers

Spring Loaded

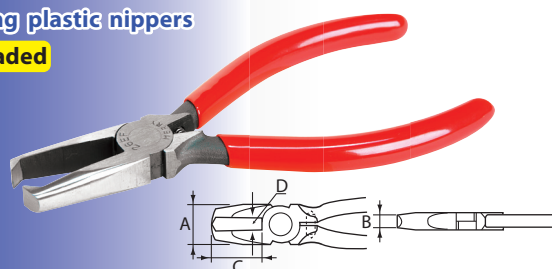

Model	Size (mm)	Dimensions (mm)				Weight (g)	Cutting capacity (φmm)	
		A	B	C	D		Plastics	
26EF	140	17.0	7.0	27.0	7.0	110	Plastics	3.0

### HW25R

R-cut plastic nippers  
<with adjustable stopper>

Spring Loaded

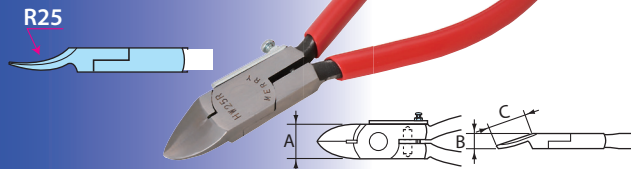

Model	Size (mm)	Dimensions (mm)			Weight (g)	Cutting capacity (φmm)	
		A	B	C		Plastics	
HW25R	150	16.0	8.5	16.0	110	Plastics	5.0



MERRY

# NIPPERS FOR CUTTING PLASTICS OTHERS



# NIPPERS FOR CUTTING PLASTICS OTHERS

Section of blade

Round type

Flat type

Angle type

## 550SF

Box joint plastic nippers

Spring Loaded

Round type

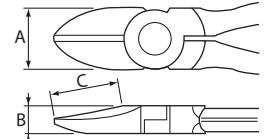
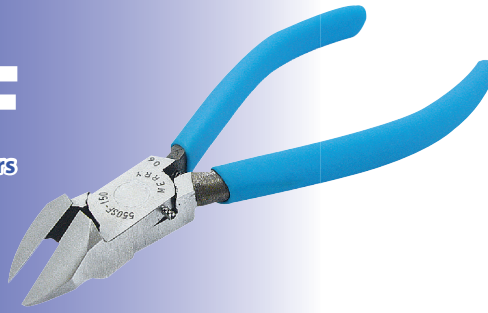

Model	Size (mm)	Dimensions(mm)			Weight (g)	Cutting capacity (φmm) Plastics
		A	B	C		
550SF-125	125	14.0	14.5	21.5	95	3.0
550SF-150	150	15.0	17.0	24.0	125	5.0

## 140S

Flat plastic nippers  
◀with adjustable stopper▶

Spring Loaded

Flat type

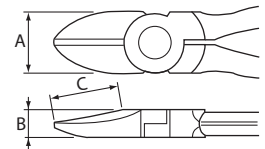
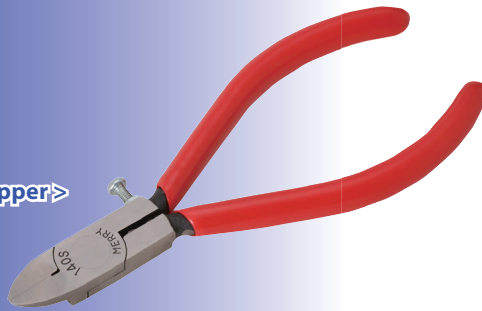

Model	Size (mm)	Dimensions(mm)			Weight (g)	Cutting capacity (φmm) Plastics
		A	B	C		
140S	130	12.5	7.5	11.0	70	3.0

## 170PL

Smooth plastic nippers

Spring Loaded

Flat type

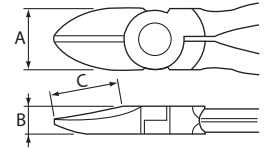

Model	Size (mm)	Dimensions(mm)			Weight (g)	Cutting capacity (φmm) Plastics
		A	B	C		
170PL	150	16.0	9.0	24.0	112	5.0

## 02SP

Tip edge nippers

Spring Loaded

Round type

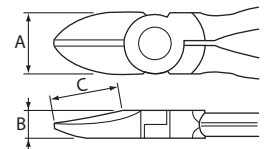
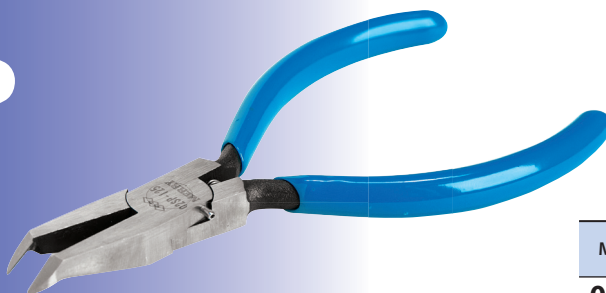

Model	Size (mm)	Dimensions(mm)			Weight (g)	Cutting capacity (φmm) Plastics
		A	B	C		
02SP	125	12.0	7.5	6.0	75	2.0

## L40

Long handle nippers

Spring Loaded

Flat type

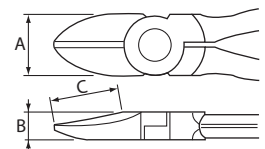
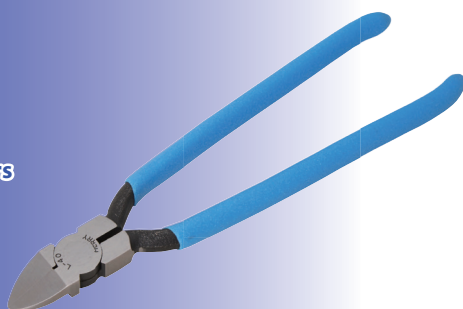

Model	Size (mm)	Dimensions(mm)			Weight (g)	Cutting capacity (φmm) Plastics
		A	B	C		
L40	190	17.0	9.0	19.0	150	5.0



MERRY

# HEAT NIPPERS FOR CUTTING PLASTICS



# HEAT NIPPERS FOR CUTTING PLASTICS

The built-in heater warms the blade edges for easier, crack-free cutting of fragile materials such as acrylics, styrene plastic, and glass resins. These heat nippers must be used with suitable transformer.



## HT180DX

<with Sensor>  
Spring Loaded



Model	Size (mm)	Weight (g)	Cutting capacity (φmm)	Blade length (mm)	Transformer	Heater
			Plastics			
HT180DX	190	310	4.0	16	TRF100D	W19

## HT120

<End cutting type>  
Spring Loaded

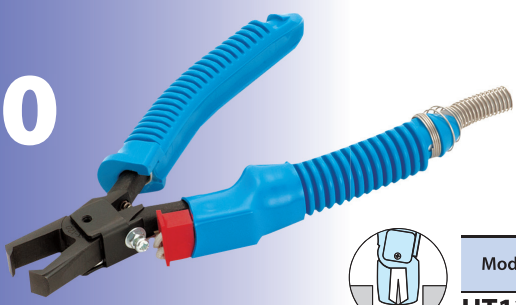

Model	Size (mm)	Weight (g)	Cutting capacity (φmm)	Blade length (mm)	Transformer	Heater
			Plastics			
HT120	150	275	4.0	10	TRF25	W19

## HT130

<Long blade type>  
Spring Loaded

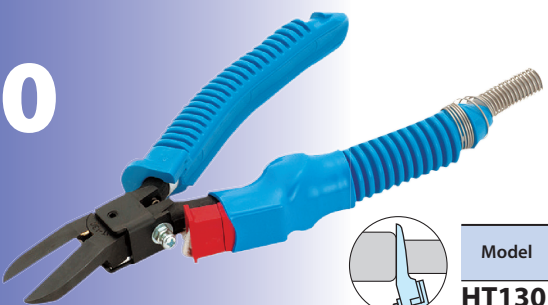
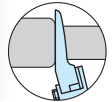

Model	Size (mm)	Weight (g)	Cutting capacity (φmm)	Blade length (mm)	Transformer	Heater
			Plastics			
HT130	165	270	4.0	27	TRF25	W19

## HT140

<Flat blade type>  
Spring Loaded

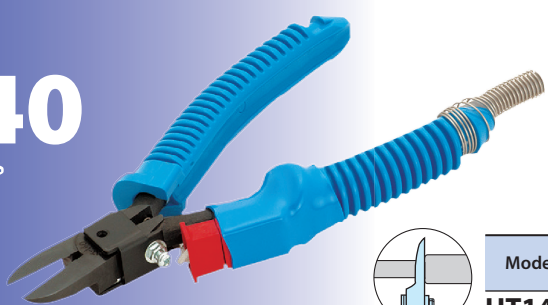
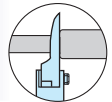

Model	Size (mm)	Weight (g)	Cutting capacity (φmm)	Blade length (mm)	Transformer	Heater
			Plastics			
HT140	160	265	4.0	22	TRF25	W19

## HT160

<for cutting narrow spaces>  
Spring Loaded

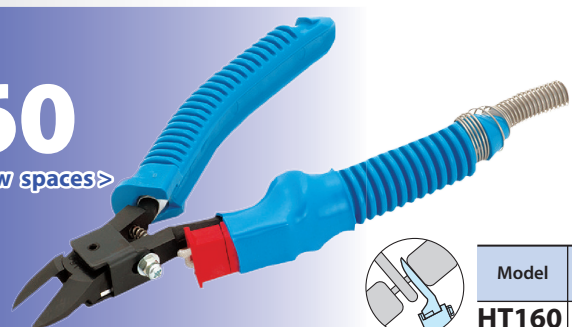

Model	Size (mm)	Weight (g)	Cutting capacity (φmm)	Blade length (mm)	Transformer	Heater
			Plastics			
HT160	150	255	4.0	16	TRF25	W19

# HEAT NIPPERS FOR CUTTING PLASTICS

Section of blade

Round type

Flat type

Angle type

## HT170

<Angle blade type>

Spring Loaded

Flat type

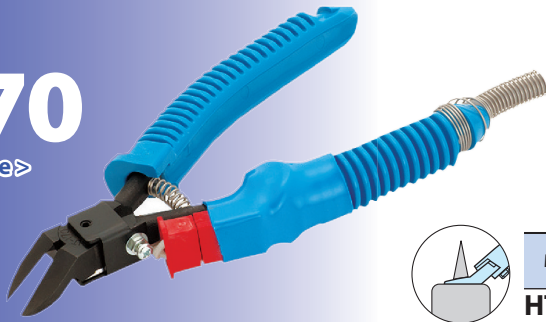

Model	Size (mm)	Weight (g)	Cutting capacity (φmm)	Blade length (mm)	Transformer	Heater
			Plastics			
<b>HT170</b>	150	275	4.0	22	TRF25	W19

## HT180

<Standard type>

Spring Loaded

Round type

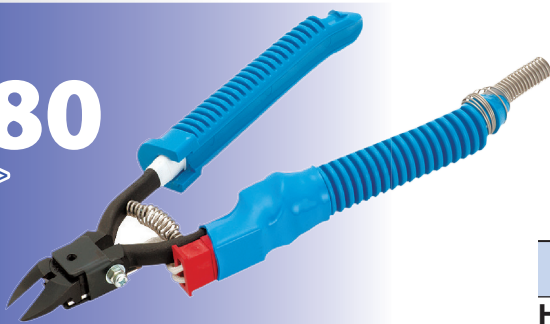

Model	Size (mm)	Weight (g)	Cutting capacity (φmm)	Blade length (mm)	Transformer	Heater
			Plastics			
<b>HT180</b>	190	295	4.0	16	TRF25	W19

## HT200

<Heavy-duty type>

Spring Loaded

Round type

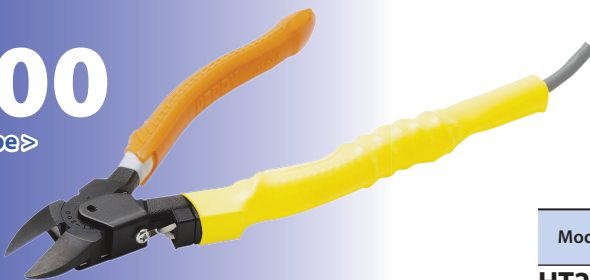

Model	Size (mm)	Weight (g)	Cutting capacity (φmm)	Blade length (mm)	Transformer	Heater
			Plastics			
<b>HT200</b>	190	375	7.0	23	TRF25	W29

## TRF25

<100V . 220V . 240V >

## TRF100D



TRF25

TRF25-120V will be sold in 2017 years



TRF100D

Model	Input power	Output power	Length of cord (m)
<b>TRF25</b>	AC100V50·60HZ	30VA MAX	1.85
<b>TRF100D</b>	AC100V50·60HZ	30VA MAX	1.83

## HDT100

<Step-Down Transformer for TRF25-100V >

## HEATER



### HEATER

W-19 <24V-19W>

W-29 <24V-29W>



Model	Input power	Output power	Length of cord (m)	Weight (g)
<b>HDT100</b>	AC220V~240V	AC 100V	1.85	950





MERRY

# SERIES THING



# SERIES THING

Section of blade

**Standard** for cutting hard wire

**Semi-flush** for cutting medium wire

**Full-flush** for cutting soft wire only or plastic, gate and sprue

## 01

Miniature nippers

Spring Loaded

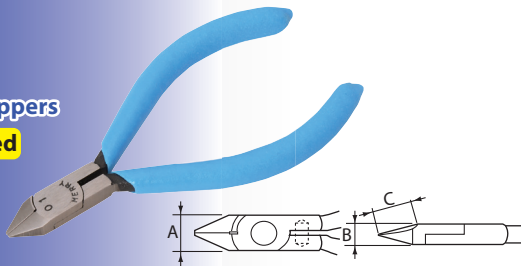

Model	Size (mm)	Dimensions (mm)			Weight (g)	Cutting capacity (φmm)	
		A	B	C		Steel wire	Copper wire
01	100	9.5	6.0	8.5	35	0.5	0.8

Semi-flush

## 06

Miniature needle pliers

Spring Loaded

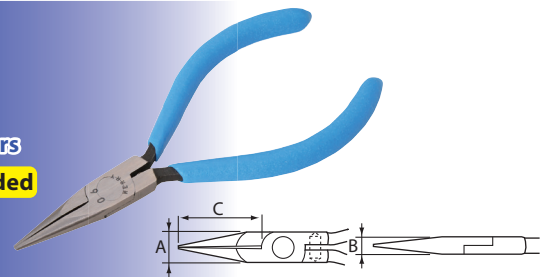

Model	Size (mm)	Dimensions (mm)			Weight (g)
		A	B	C	
06	110	9.5	6.0	23.0	40

1.0  
1.6

## 02

Miniature nippers <Tip edge type>

Spring Loaded

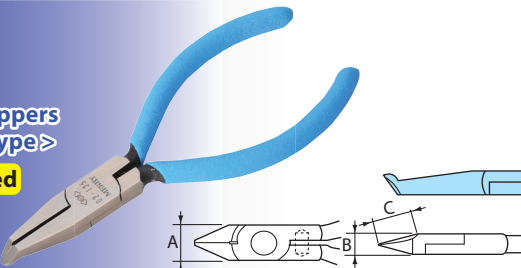

Model	Size (mm)	Dimensions (mm)			Weight (g)	Cutting capacity (φmm)	
		A	B	C		Steel wire	Copper wire
02	125	11.5	7.5	6.0	55	0.5	0.8

Semi-flush

## 07

Miniature bent nose pliers

Spring Loaded

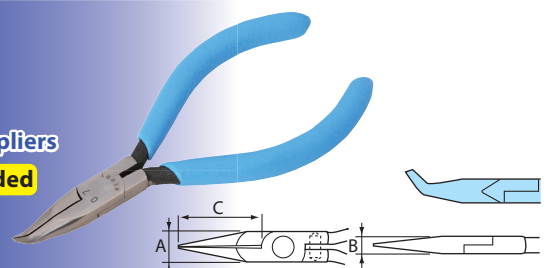

Model	Size (mm)	Dimensions (mm)			Weight (g)
		A	B	C	
07	110	9.5	5.5	21.0	40

1.0  
1.6

## 03

Miniature nippers

Spring Loaded

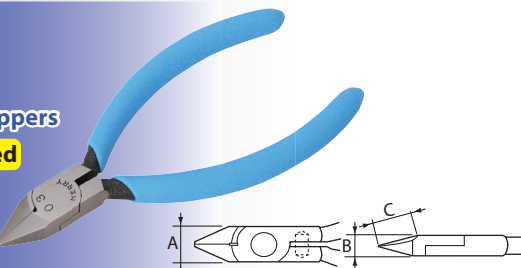

Model	Size (mm)	Dimensions (mm)			Weight (g)	Cutting capacity (φmm)	
		A	B	C		Steel wire	Copper wire
03	100	10.5	7.0	11.0	45	0.5	0.8

Semi-flush

## 08

Miniature flat nose pliers

Spring Loaded

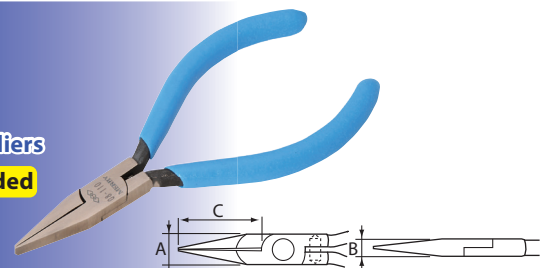

Model	Size (mm)	Dimensions (mm)			Weight (g)
		A	B	C	
08	110	9.5	6.0	22.0	40

4.0  
1.2

## 04

Miniature nippers

Spring Loaded

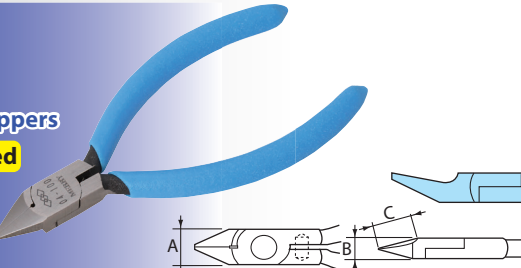

Model	Size (mm)	Dimensions (mm)			Weight (g)	Cutting capacity (φmm)	
		A	B	C		Steel wire	Copper wire
04	100	10.5	7.0	10.0	45	0.5	0.8

Semi-flush

## 09

Miniature semi needle pliers

Spring Loaded

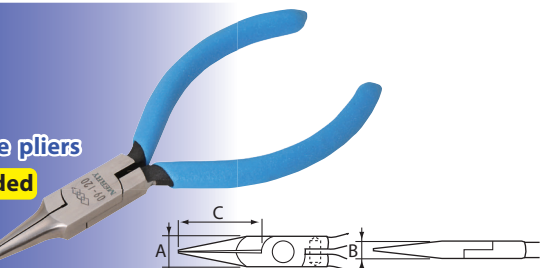

Model	Size (mm)	Dimensions (mm)			Weight (g)
		A	B	C	
09	120	11.0	7.5	32.0	40

1.5  
2.0

## 05

Miniature nippers <with stripping hole>

Spring Loaded

φ1.2

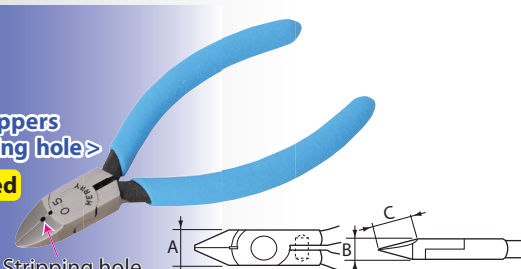

Model	Size (mm)	Dimensions (mm)			Weight (g)	Cutting capacity (φmm)	
		A	B	C		Steel wire	Copper wire
05	100	10.5	7.0	11.0	45	0.5	0.8

Semi-flush

## M10

Miniature long needle pliers

Spring Loaded

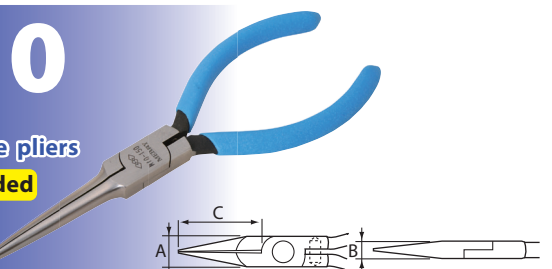

Model	Size (mm)	Dimensions (mm)			Weight (g)
		A	B	C	
M10	150	12.0	7.0	58.0	65

2.0  
2.0

# SERIES THING

Section of blade

Standard  Semi-flush  Full-flush  Round type  Flat type  Angle type 

## M11

Miniature plastic cutting nippers

Spring Loaded

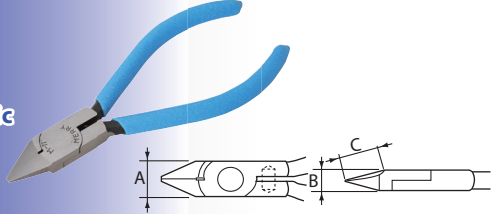

Model	Size (mm)	Dimensions (mm)			Weight (g)	Cutting capacity (φmm)	
		A	B	C		Plastics	3.0
M11	125	14.0	8.0	15.0	75		

Round type 

## M12

Miniature plastic cutting nippers

Spring Loaded

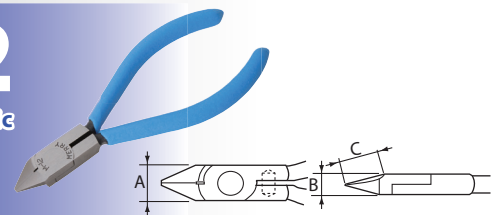

Model	Size (mm)	Dimensions (mm)			Weight (g)	Cutting capacity (φmm)	
		A	B	C		Plastics	3.0
M12	125	12.5	8.5	12.0	75		

Round type 

## M13

Miniature needle pliers

Spring Loaded

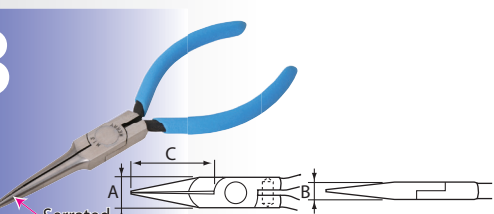

Model	Size (mm)	Dimensions (mm)			Weight (g)
		A	B	C	
M13	140	12.0	7.0	47.0	70

Serrated



## M14

Miniature side cutting pliers

Spring Loaded

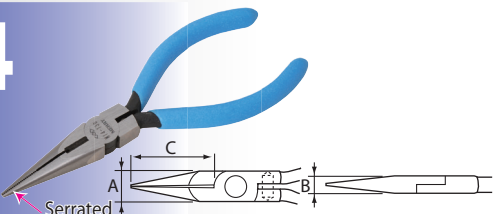

Model	Size (mm)	Dimensions (mm)			Weight (g)	Cutting capacity (φmm)	
		A	B	C		Steel wire	Copper wire
M14	130	13.5	8.0	37.0	60	1.2	2.0

Serrated



## M15

Miniature chain nose pliers

Spring Loaded

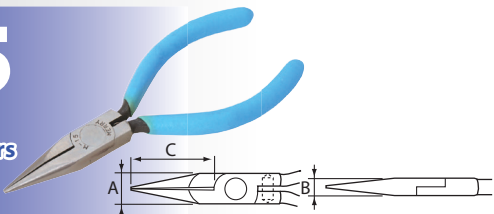

Model	Size (mm)	Dimensions (mm)			Weight (g)
		A	B	C	
M15	125	12.0	7.5	30.0	60



## M16

Miniature end cutting nippers

Spring Loaded

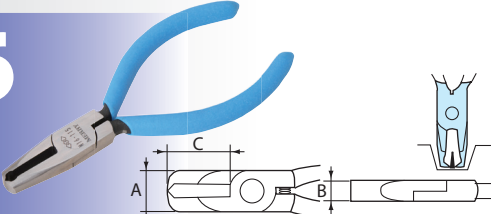

Model	Size (mm)	Dimensions (mm)			Weight (g)	Cutting capacity (φmm)	
		A	B	C		Steel wire	Copper wire
M16	115	12.0	7.0	21.0	60	0.5	0.8

Semi-flush 

## L30

Long handle cutting nippers

Spring Loaded

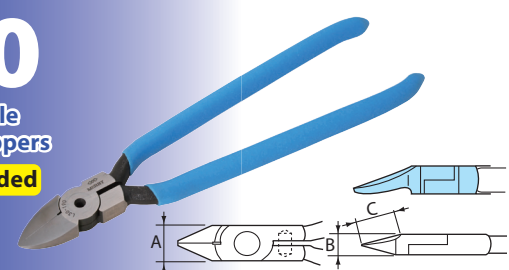

Model	Size (mm)	Dimensions (mm)			Weight (g)	Cutting capacity (φmm)	
		A	B	C		Steel wire	Copper wire
L30	190	17.0	9.0	19.0	150	1.2	2.0

Semi-flush 

## L40

Long handle plastics cutting nippers

Spring Loaded

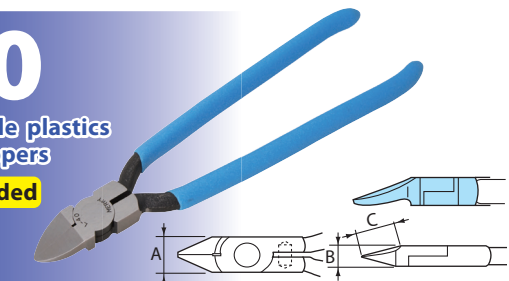

Model	Size (mm)	Dimensions (mm)			Weight (g)	Cutting capacity (φmm)	
		A	B	C		Plastics	5.0
L40	190	17.0	9.0	19.0	150		

Flat type 

## L50

Long handle needle pliers

Spring Loaded

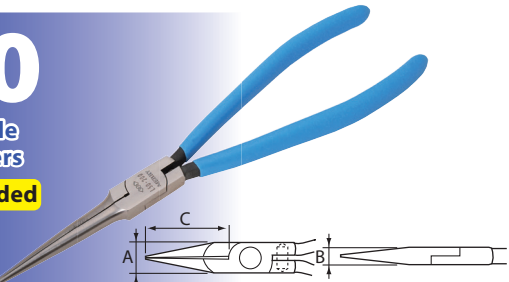

Model	Size (mm)	Dimensions (mm)			Weight (g)
		A	B	C	
L50	200	12.0	7.5	55.0	110



## L60

Long handle bent nose pliers

Spring Loaded

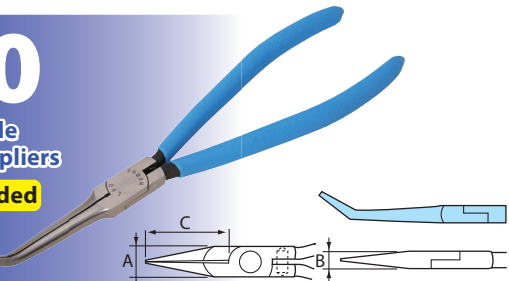

Model	Size (mm)	Dimensions (mm)			Weight (g)
		A	B	C	
L60	200	12.0	7.5	53.0	110



## L70

Long handle flat nose pliers

Spring Loaded

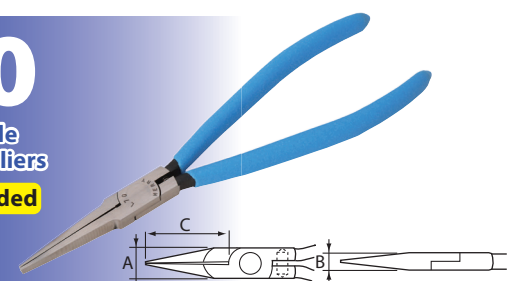

Model	Size (mm)	Dimensions (mm)			Weight (g)
		A	B	C	
L70	185	11.5	7.0	42.0	110





MERRY

# CLIP PLIERS SNAP RING PLIERS DUCT CUTTERS



# CLIP PLIERS/SNAP RING PLIERS/ DUCT CUTTERS

Section of blade

Round type

Flat type

Angle type

## JR60

<for automotive garage>

Spring Loaded

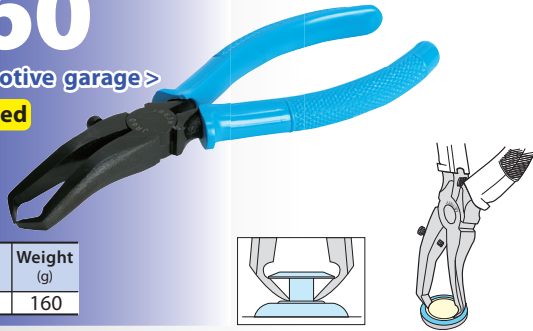

Model	Size (mm)	Weight (g)
JR60	155	160

## JR80

Spring Loaded

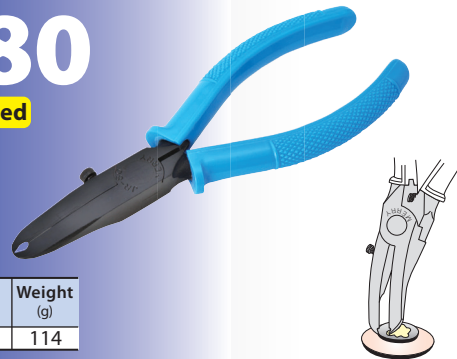

Model	Size (mm)	Weight (g)
JR80	155	114

## HS175C

Spring Loaded

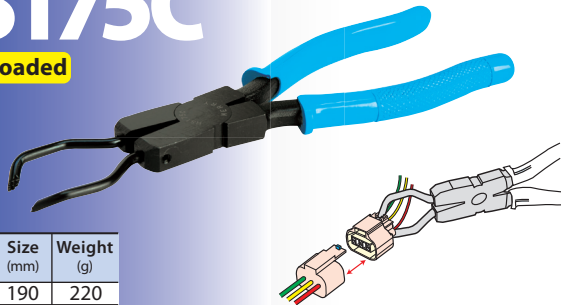

Model	Size (mm)	Weight (g)
HS175C	190	220

## HS175A

<Adjustable for setting gap>  
<with straight pin (3set) for hole>

Spring Loaded



Model	Size (mm)	Weight (g)
HS175A	200	190

## JS175A

<Adjustable for setting gap>  
<with straight pin (3set) for shaft>

Spring Loaded

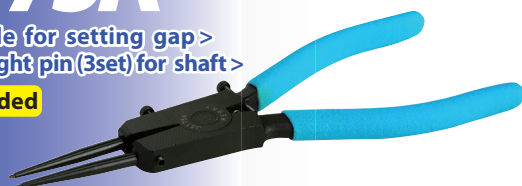

Model	Size (mm)	Weight (g)
JS175A	200	190

## JC175B

<Adjustable for setting gap>  
<with straight pin (5set) for shaft>

Spring Loaded



Model	Size (mm)	Weight (g)
JC175B	190	187

## HC175B

<Adjustable for setting gap>  
<with straight pin (5set) for shaft>

Spring Loaded



Model	Size (mm)	Weight (g)
HC175B	190	190

## DK55 DK65

<End cutting type>

Spring Loaded

Round type

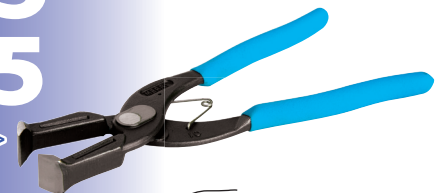

Model	Size (mm)	Dimensions (mm)			Weight (g)	Cutting capacity (φmm)
		A	B	C		
DK55	250	21.5	55.0	510	8.0	
DK65	250	21.5	65.0	490	8.0	

## CK20

<Cable cutters>



Model	Size (mm)	Dimensions (mm)			Weight (g)	Cutting capacity (φmm)
		A	B	C		
CK20	215	40.0	14.0	24.0	313	IV wire 60



MERRY

# PLASTIC PIPE CUTTERS



# PLASTIC PIPE CUTTERS

## PIP19

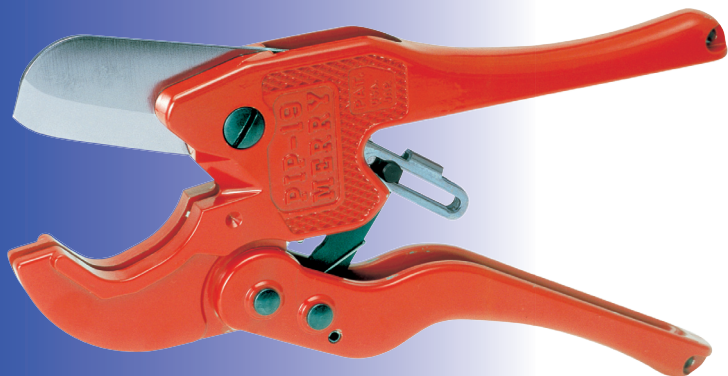

Possible to cut plastic surface raceway at any desired angle with an attachment installed.



AT-PIP19



Model	Overall length (mm)	Weight (g)	Cutting capacity (φmm)	Blade
<b>PIP19</b>	217	360	42	P18Z

## PIP42



Blade can be locked with Stopper when off-work for security. Blade-opening by pushing Release Lever down.

Possible to cut plastic surface raceway at any desired angle with an attachment installed.



AT-PIP42



Blade:P42

Model	Overall length (mm)	Weight (g)	Cutting capacity (φmm)	Blade
<b>PIP42</b>	220	340	42	P42

## PIP63



Light weight design (480g),  
Easy to grasp grip.



Model	Overall length (mm)	Weight (g)	Cutting capacity (φmm)	Blade
<b>PIP63</b>	280	496	PVC pipe 42 / VP pipe 30 VW pipe 30 / VE pipe 36	P63

# PLASTIC PIPE CUTTERS

## PIP7Z

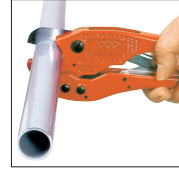

Model	Overall length (mm)	Weight (g)	Cutting capacity (φmm)	Blade
<b>PIP7Z</b>	185	270	26	P7

## FL38N

Light in weight and compact in design for comfortable one-hand operation.



Model	Overall length (mm)	Weight (g)	Cutting capacity (φmm)	Blade
<b>FL38N</b>	220	150	Reinforced flexible conduits up to φ38mm o.d.	FP38

## FL50

Light in weight and compact in design for comfortable one-hand operation.



Model	Overall length (mm)	Weight (g)	Cutting capacity (φmm)	Blade
<b>FL50</b>	250	425	Reinforced flexible conduits up to φ55mm o.d.	FP50

## MC80

Suitable for cutting plumbing materials such as bridge polyethylene tube and CD tube especially for water supply or hot water supply construction.

◀ for water piping service ▶



Holding space can be adjusted through adjusting Screw up to Max. width of 18mm.



The symmetrical type blade C80 can be used on both sides alternatively when one side is worn.



Silicon hose (up to φ34)

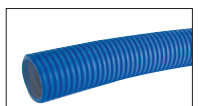

CD tube (up to φ34)

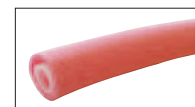

Bridge polyethylene tube (up to φ34)

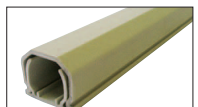

Protector

Model	Overall length (mm)	Weight (g)	Blade
<b>MC80</b>	233	225	C80





MERRY

# DUCT AND MOULD CUTTERS MERRY CUTTERS



# DUCT AND MOULD CUTTERS MERRY CUTTERS

Designed for one-hand operation. Suitable for soft materials.

## SX5

< Slim type >



Model	Overall length (mm)	Weight (g)	Blade length (mm)	Blade	Plastic plate
<b>SX5</b>	195	140	53	X5	PB-SX5

## SX7

< Ratchet type >

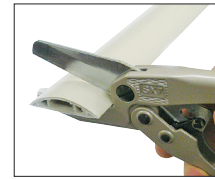

Cutting of cable protector



3-step ratchet mechanism

Model	Overall length (mm)	Weight (g)	Blade length (mm)	Blade	Plastic plate
<b>SX7</b>	230	215	65	X7	PB-SX7

## SX10

< Heavy-duty type >



Cutting nylon hose, rubber hose, soft cable wire, plastic channel, leather belt, etc

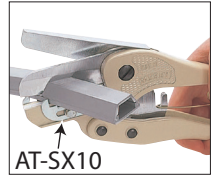

AT-SX10  
Cutting of plastic protector

Model	Overall length (mm)	Weight (g)	Blade length (mm)	Blade	Plastic plate
<b>SX10</b>	210	340	65	X10	PB-SX10

## SX20

< Long blade type >

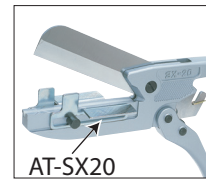
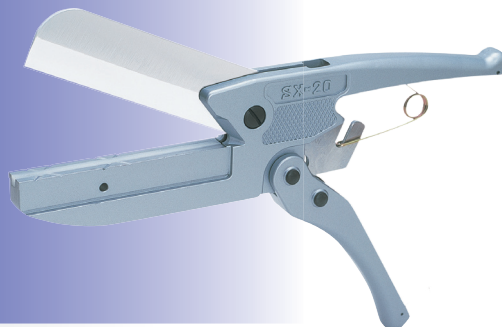

AT-SX20  
An attachment is available for right and 45° angle cutting. (Standard accessory)

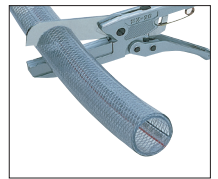

Cutting of nylon hoses

Model	Overall length (mm)	Weight (g)	Blade length (mm)	Blade	Plastic plate
<b>SX20</b>	285	535	110	X20	PB-SX20

### Examples of subjects for cutting



■ Protector



■ Nylon hose



■ Electric wire  
(Twisted wire)



■ Tree branch



■ Plastic cable protector

# DUCT AND MOULD CUTTERS MERRY CUTTERS

## SX15

< Standard type >

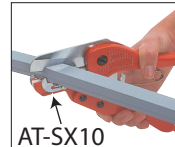

AT-SX10  
Possible to cut plastic surface protector at any desired angle with an optional attachment installed.

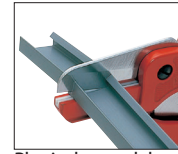

Plastic duct and duct cover

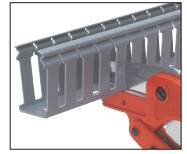

Model	Overall length (mm)	Weight (g)	Blade length (mm)	Blade	Plastic plate
<b>SX15</b>	210	335	65	X15	PB-SX15

## SX25

< Long blade type >

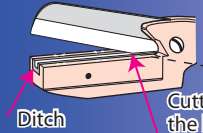

Cutting from the root of the blade gradually.

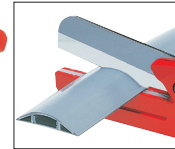
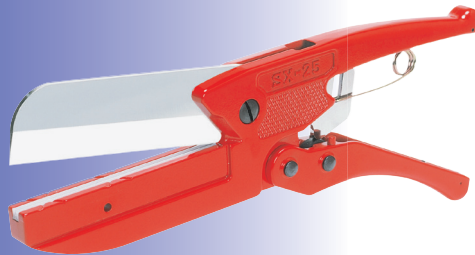

Cutting flat and wide cable protector.

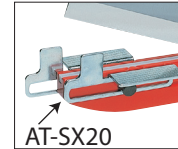

AT-SX20  
An attachment is available, for right and 45° angle cutting.(standard accessory)



Cutting plastic duct of up to 80mm in width.

Model	Overall length (mm)	Weight (g)	Blade length (mm)	Blade	Plastic plate
<b>SX25</b>	285	535	110	X25	PB-SX25

## DX80

< Ratchet type >

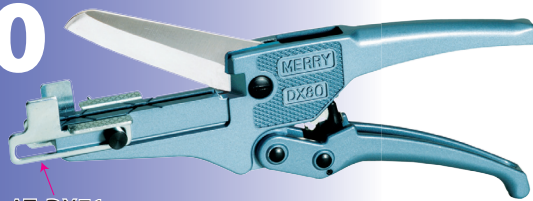

AT-DX71

3-step ratcheting

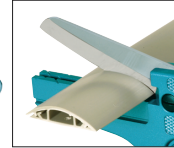

Cutting cable protector

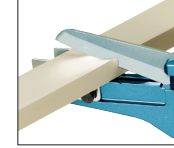

An attachment is available, for right and 45° angle cutting.(standard accessory)



Cutting plastic duct of up to 80mm in width

Model	Overall length (mm)	Weight (g)	Blade length (mm)	Blade
<b>DX80</b>	255	365	92	X80

## GCX5

No obstacle on the blade surface secures close contact with the subject to make clean cutting finish.



- Suitable for cutting wide film gate.
- Indispensable in resin molding works.
- Cutting for various kinds of soft materials.
- A Roller is installed to boost action of blade to assure sharp and fine cutting with less manual power.



Cutting film gate

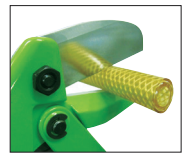

Cutting hose



Model	Overall length (mm)	Weight (g)	Blade	Plastic plate
<b>GCX5</b>	170	185	GC5	PB-GCX5

## LDC110

< Long duct cutter >



AT-LDC110



Model	Overall length (mm)	Weight (g)	Blade
<b>LDC110</b>	322	700	LD110



MERRY

# STRIPPERS



# STRIPPERS

## VST80

< for VVF wire >



Blade adjusting dial is installed for adjustment of blade opening.



Applicable to 4 different sizes of VVF wires  
( $\phi 1.6 \times 2$ ,  $\phi 1.6 \times 3$ ,  $\phi 2.0 \times 2$ ,  $\phi 2.0 \times 3$ )

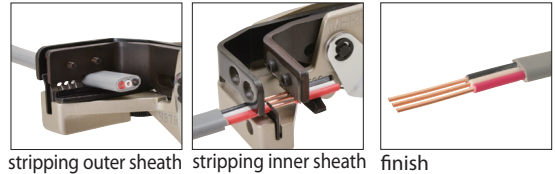

stripping outer sheath stripping inner sheath finish

Model	Overall length (mm)	Weight (g)	Blade
<b>VST80</b>	190	380	VB80

## VST50

< for VVF wire >

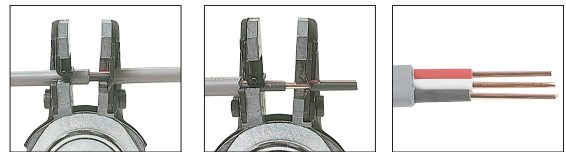

Model	Overall length (mm)	Weight (g)	Cutting capacity ( $\phi$ mm) (VVF)(Outer coat)	Blade
<b>VST50</b>	185	451	1.6 2core wire/2.0 2core wire 1.6 3core wire/2.0 3core wire	VS51

## VST25

< Mini wire stripper >

PAT. & PAT. P. in:  
Japan, USA, Canada, Australia, UK,  
France, Germany, Italy & Korea.



Handy stripper for non-step operation.

Applicable to single and multi-core wires of 0.05mm ~ 3.5mm ( $\phi 0.25 \sim 2.6$ mm). (Stripping length can be adjusted.)

Slim and long head permits operation in narrow spaces.

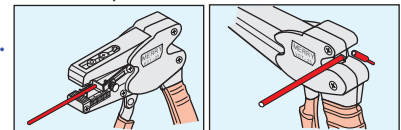

The V-shaped stripping blade allows easy clutching of the wire. Wire cutting function is additionally provided.

Model	Overall length (mm)	Weight (g)	Stripping capacity (mm <sup>2</sup> )	Blade	Cutting capacity ( $\phi$ mm)	Blade
<b>VST25</b>	120	260	0.05~3.5 (AWG30~10)	VS20	2.6	VC25

## LW25

< Heavy-duty cable stripper >  
< Light in weight >

No experienced professional skill is needed to strip large cables. Quick, safe and easy stripping achievement is assured.

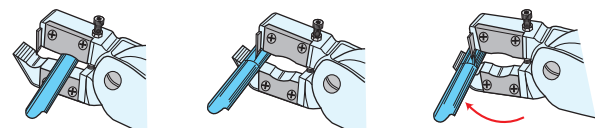
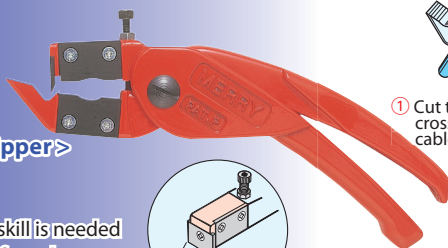
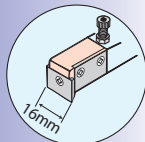

- 1 Cut the wire protector crosswise by turning the cable several times.
- 2 Slit the wire protector length wise.
- 3 Strip out the cut skin of the protector with the blade by turning the cable. Use hand pliers when necessary.

Model	Overall length (mm)	Weight (g)	Stripping capacity	Blade Cross wise	Blade Length wise
<b>LW25</b>	180	210	Maximum $\phi$ 25mm of cable protector Minimum $\phi$ 8mm of core cable	LW25-1	LW25-2

## SST50

< Solar cable stripper >



It can be stripping easily.



First Stripping  
Second Stripping (For both First and Second Stripping)

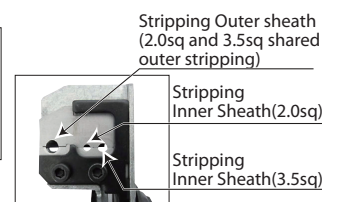

Stripping Outer sheath (2.0sq and 3.5sq shared outer stripping)

Stripping Inner Sheath(2.0sq)

Stripping Inner Sheath(3.5sq)

Model	Overall length (mm)	Weight (g)	Cutting capacity ( $\phi$ mm) (H-CV)(Outer coat)	Blade
<b>SST50</b>	185	448	2.0sq/3.5sq	SS51



MERRY

# OTHERS



# OTHERS

## CASSETTE PLIERS

Blades can be easily replaced.  
Blade opening is adjustable.

Setting precise & small parts  
Cutting fine wires  
Assembling plastic hobby models  
Repairing appliances

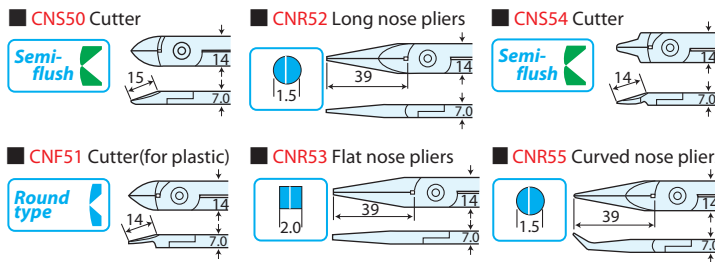

Model	Weight (g)	Blade	Cutting capacity (φmm)	Model	Weight (g)	Blade	Cutting capacity (φmm)
CNS-50	105	CNS50	copper 1.0 steel 0.5	CNS-53	110	CNR53	—
CNS-51	105	CNF51	plastic(only) 2.0	CNS-54	105	CNS54	copper 1.0 steel 0.5
CNS-52	110	CNR52	—	CNS-55	110	CNR55	—

## BARRIER WRENCHES

The unique "MERRY" Barrier Wrenches have solved the problem of difficult bolt/nut fastening and loosening jobs in narrow and hard-to-reach places.

### AN EXAMPLE OF APPLICATION

Barrier Wrenches offer safe and smooth service for replacement or adjustment of the cultivator blades in narrow space.

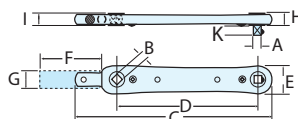

General use with ratchet wrench  
Impact Wrench can be used instead of a ratchet wrench **only for YL2.** (Torque should not exceed 180N·m.)

Model	Square size A×B	Weight (g)	Max. allowable torque(N·m)
YL1A	□ 9.5□ × □ 9.5□	820	94
YL2	□ 12.7□ × □ 12.7□	1,330	196

Model	Dimensions(mm)							
	C	D	E	F	G	H	I	K
YL1A	300	217	39	150	φ20	18	22	10
YL2	327	228	49	210	φ26	20	25	14

## FBP30

Fish boning pliers



### HOW TO DISASSEMBLE THE CROSS-STICKS

1. Disconnect either end of the plastic spring.
2. Shift the joint-Screw from small hole to large one.

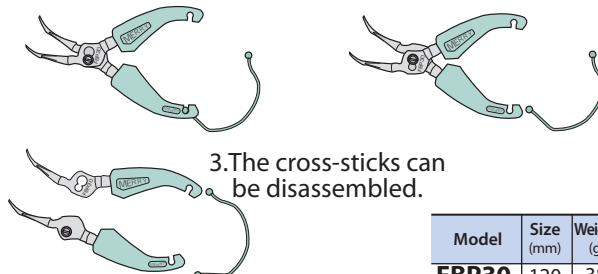

3. The cross-sticks can be disassembled.

Model	Size (mm)	Weight (g)
FBP30	120	38

## HN22

Precision palm pliers



〈Stainless steel〉 Needle-nose pliers with a curved palm grip

Perfect for removing bones in fish processing factories.

Model	Size (mm)	Weight (g)
HN22	105	41

### SPRINGS FOR MERRY NIPPERS AND CUTTERS

Model	Order Quantity	Adaptable Type
MBN-01	10P	55S-120, 160S-125, 02, 09, M11, M12, M14, etc
MBN-02	10P	55S-150, 160S-150, 66S, CT55-150, etc
MBN-03	10P	99-175/200, 206S-175/200, etc
MBN-04	10P	01, 03, 04, 05, 06, 07, 08
MBN-05	10P	L30, L40, HT160, 170S, etc
MBN-06	10P	105-150, 23EF, 25EF, 26EF

Model	Order Quantity	Adaptable Type
MBN-07	10P	99-150, 206S-150, HT120, HT130, HT140
MBN-08	10P	HT180
MBN-09	10P	HT200
MBN-10	5P	PIP19
MBN-11	5P	SX5
MBN-12	5P	SX10, SX15

# MODEL NUMBER INDEX



# MODEL NUMBER INDEX

## 0

01	79
02	79
02SP	74
03	79
04	79
05	79
06	79
07	79
08	79
09	79

## 1

100	51
105-150	64
105-175	64
1050-150	55
1050-175	55
1050-200	55
1050H-150	55
1050H-175	55
1050H-200	55
105F-150	64
105F-175	64
105H-150	64
105H-175	64
10M	40
10MC	40
140S	74
150	64
160FW-125	67
160FW-150	67
160GT	67
160S-125	67
160S-150	67
160SA-125	67
160SA-150	67
160SF-125	67
160SF-150	67
170PL	74
170S	69
1800	51

## 2

200	51
2000EF	72
203	62
205-150	58
205-175	58
205-200	58
2050-185	55
2050-225	55
205H-150	58
205H-175	58
205H-200	58
205T-150	60
205T-175	60
205T-200	60
2060	55
2060N	55
2060U	55
206S-150	58
206S-175	58
206S-200	58
207	58
2070	56
2080-185	56
2080-210	56
2080N-185	56

## 2

2080N-210	56
23EF	72
24EF	72
2500	65
2500R	65
2500T	65
25EF	72
26EF	72

## 3

300	51
305-7	60
305-8	60
3300	51

## 4

400	51
405-7	59
405-8	59
405-9	59
450-125	60
450-150	60

## 5

550-150	59
550-175	59
550SF-125	74
550SF-150	74
55S-120	59
55S-150	59
55S-PM-120	59
55S-PM-150	59

## 6

600	51
6050	56
66S	70
68S	70

## 7

750	51
-----	----

## 8

8050-185	56
8050-210	56

## 9

99-150	69
99-175	69
99-200	69
99S-150	69
99S-175	69
99S-200	69
99SF-150	69
99SF-175	69
99SF-200	69
99W-150	59
99W-175	59
99W-200	59

## A

A8P-1.25	7
----------	---

## A

A8P-2.0	7
A8P-5.5	7
A8P1-1.25	7
A8P1-2.0	7
A8WP-1.25-2.0	7
A8WP-2.0-5.5	7
AF1032	42
AF10S	42
AF5A	42
AF5F	42
AF7	42
AF7S	42
AFF50	42
AFH50	42
AFR50	42
AFT50	42
AH20	35
AH30	35
AH5	34
AH5D	34
AH8	34
AH8D	34
AM10	39
AM20	39
AM3	39
AR8P-1.25	7
AR8P-2.0	7
AR8P-5.5	7
AR8P1-1.25	7
AR8P1-2.0	7
AR8WP-1.25-2.0	7
AR8WP-2.0-5.5	7
AS100	39
AS200	39
ASP150	39
ASP250	39
AT-DX71	88
AT-LDC110	88
AT-PIP19	84
AT-PIP42	84
AT-SX10	87 • 88
AT-SX20	87 • 88

## C

C80	85
CB13L	37
CB13S	37
CF10	23
CF20	23
CF5	23
CHL20	52
CHL30	52
CHL40	52
CHL50	52
CHL60	52
CK20	82
CL10	23
CL20	23
CL5	23
CN5-50	92
CN5-51	92
CN5-52	92
CN5-53	92
CN5-54	92
CN5-55	92
CNF51	92
CNR52	92
CNR53	92
CNR55	92

## C

CNS54	92
CNS50	92
CP10	12
CP10M	16
CP20	12
CP20M	16
CP20X	12
CP20XM	16
CP30	12
CP30M	16
CP30X	12
CP30XM	16
CR120	5
CR2	5
CR20	5
CR250	5
CR4	5
CR400	12 • 16
CR6	5
CR600	12 • 16
CR6A	5
CR800	12 • 16
CR8P	5
CR8P1	5
CST100	48
CST100L	49
CST110	49
CST120	49
CST35	48
CT160F-125	67
CT160F-150	67
CT305-7	62
CT305-8	62
CT55-120	62
CT55-150	62
CTD20	32
CTD30	32
CX25R	72

## D

DK55	82
DK65	82
DX80	88

## E

E250	40
E250H	40
E250S	40
E300	40
E300H	40
E300S	40
E300ZN	40
EP100	12 • 16
EP10P	5
EP10P1	5
EP120	5
EP2	5
EP20	5
EP4	5
EP400	12 • 16
EP6	5
EP600	12 • 16
EP6A	5

## F

F1	6
F10	6

# MODEL NUMBER INDEX

<b>F</b>		<b>F</b>		<b>H</b>		<b>M</b>	
F10E	22 • 29	FG5K	29	HS175C	82	ME30	29
F10EK	22 • 29	FL38N	85	HT120	76	ME5	29
F10S	6	FL50	85	HT130	76	MF10	22
F120	6	FN1	25 • 26	HT140	76	MF20	22
F1E	22 • 29	FN10	25 • 26	HT160	76	MF3	22
F1EK	22 • 29	FN10C	26	HT170	77	MF5	22
F1S	6	FN10K	27	HT180	77	MG10	29
F250	6	FN10L	27	HT180DX	76	MG20	29
F250S	6	FN1C	26	HT200	77	MG3	29
F3	6	FN1K	27	HTR100W	35	ML10	29
F300	12 • 16	FN1L	27	HW25R	72	ML20	29
F3E	22 • 29	FN3	25 • 26			ML30	29
F3EK	22 • 29	FN30	26	<b>J</b>		MP10	11
F3LS	6	FN30C	26	JC175B	82	MP10M	14
F3S	6 • 29	FN30K	27	JR60	82	MP25	11
F5	6	FN30L	27	JR80	82	MP250M	14
F500	12 • 16	FN3C	26	JS175A	82	MP25A	11
F5A	6	FN3K	27			MP25AM	14
F5AS	6	FN3L	27	<b>K</b>		MP25AMG	15
F5E	22 • 29	FN5	25 • 26	K6	7	MP25M	14
F5EK	22 • 29	FN5C	26	K6A	7	MP3	11
F5J	6	FN5K	27	K6J	7	MP35A	11
F5JS	6	FN5L	27	K8P	7	MP35AM	14
F5LS	6	FNP1	25 • 26	K8P1	7	MP35AMG	15
F5S	6 • 29	FNP10	25 • 26			MP3M	14
F900	12 • 16	FNP10C	26	<b>L</b>		MP5	11
F9E	29	FNP1C	26	L30	80	MP55AK	11
F9EK	29	FNP3	25 • 26	L40	74 • 80	MP55AM	14
F9P	6	FNP30	26	L50	80	MP5M	14
F9P1	6	FNP30C	26	L60	80	MR10	11
F9P1S	6	FNP3C	26	L70	80	MR10M	14
F9PF	6	FNP5	25 • 26	LD110	88	MR20	11
F9PS	6 • 29	FNP5C	26	LDC110	88	MR20M	14
FA20C	35	FP38	85	LW25	90	MR20MG	15
FA20L	35	FP50	85	LW25-1	90	MR3	11
FA20S	35	FT7	6	LW25-2	90	MR30A	11
FA30C	35	FT7S	6			MR30AM	14
FA30L	35	FW1	20	<b>M</b>		MR30AMG	15
FA30S	35	FW10	20	M10	79	MR3M	14
FA5	34	FW10S	20	M11	70 • 80	MR5	11
FA8	34	FW1S	20	M12	70 • 80	MR50AK	11
FB70S	32	FW3	20	M13	80	MR50AM	14
FBP30	92	FW3S	20	M14	80	MR50FK	11
FD1	6	FW5	20	M15	80	MR50FM	14
FD10	6	FW5S	20	M16	80	MR5M	14
FD250	6			M20	51	MS10	18
FD3	6	<b>G</b>		M40	51	MS10AG	19
FD300	12 • 16	G1000	51	M60	51	MS10G	19
FD5	6	G1500	51	MB20	44	MS10V	21
FD500	12 • 16	G2000	51	MB20S	44	MS20	18
FD5A	6	G500	51	MBN-01	92	MS20G	19
FD5J	6	G750	51	MBN-02	92	MS20V	21
FD7	6	GC5	88	MBN-03	92	MS3	18
FD900	12 • 16	GCX5	88	MBN-04	92	MS30	18
FD9P	6	GS01	40	MBN-05	92	MS30G	19
FD9P1	6	GS02	40	MBN-06	92	MS30V	21
FD9PF	6	GS650	52	MBN-07	92	MS3G	19
FEP10P	7	GS750	52	MBN-08	92	MS5	18
FEP10P1	7	GS850	52	MBN-09	92	MS50	18
FEP2	7	GS950	52	MBN-10	92	MS50F	18
FEP20	7	GXT1000	45	MBN-11	92	MS5G	19
FEP4	7	GXT1200	45	MBN-12	92	MSB10	21
FEP6	7			MC80	85	MSB20	21
FEP6A	7	<b>H</b>		ME10	29	MSB30	21
FEP7	7	HC175B	82	ME20	29	MSK10	20
FG10	29	HDT100	77	ME3	29	MSK20	20
FG10K	29	HN22	92			MSK30	20
FG3	29	HS175A	82			MSP10	18
FG3K	29					MSP10AG	19
FG5	29						

# MODEL NUMBER INDEX

<b>M</b>		<b>S</b>		<b>T</b>		<b>Y</b>	
MSP10G	19	S2	5	TRF25	34 • 77	YL2	92
MSP20	18	S20	5	TU01	32	YT7	7
MSP20G	19	S20S	5				
MSP3	18	S250	5	<b>U</b>		<b>Z</b>	
MSP30	18	S250S	5	UH10	52	Z120	5
MSP30G	19	S2S	5	UH2	52	Z120S	6
MSP3G	19	S4	5	UH3	52	Z2	5
MSP5	18	S400	12 • 16	UH5	52	Z20	5
MSP50	18	S4S	5	UH7	52	Z20S	6
MSP5G	19	S5	5			Z2S	6
		S500	12 • 16	<b>V</b>		Z4	5
		S5A	5	VB80	90	Z400	12 • 16
		S5AS	5	VC25	90	Z4S	6
		S5S	5	VOHR10	45	Z6	5
<b>N</b>		S700	12 • 16	VOHR5	45	Z600	12 • 16
No.100R	39	S7P	5	VS20	90	Z6A	5
No.100S	39	S7P1	5	VS51	90	Z6AS	6
No.200R	39	S7P1S	5	VST25	90	Z6JS	6
No.200S	39	S7PS	5	VST50	90	Z6S	6
No.30S	39	S900	12 • 16	VST80	90	Z800	12 • 16
		S9P	5			Z8P	5
		S9P1	5	<b>W</b>		Z8P1	5
		S9PS	5	W-19	34 • 77	Z8PS	6
		SE30	52	W-19W	35	ZA185	65
		SE40	52	W-29	77	ZCR120	6
		SE50	52	W1014	42	ZCR2	6
		SE60	52	WA1000	60	ZCR20	6
		SE70	52	WK10	45	ZCR4	6
		SE80	52	WK30N	45	ZCR6	6
		SH8P	7	WS10	20	ZCR6A	6
		SN1	25	WS20	20	ZCR6J	6
		SN10	25	WS3	20	ZCR7	6
		SN2	25	WS5	20	ZCR8P	6
		SN20	25			ZCR8P1	6
		SN3	25	<b>X</b>		ZEP10P	6
		SN5	25	X10	87	ZEP10P1	6
		SNP1	25	X15	88	ZEP120	6
		SNP10	25	X160-125	67	ZEP2	6
		SNP2	25	X160-150	67	ZEP20	6
		SNP20	25	X20	87	ZEP4	6
		SNP3	25	XP200	56	ZEP6	6
		SNP5	25	X25	88	ZEP6A	6
		SR1036	42	X5	87	ZEP6J	6
		SS51	90	X7	87	ZEP7	6
		SST50	90	X80	88	ZFN1	27
		SVM10M	31	XN200	60	ZFN10	27
		SVM20	31			ZFN3	27
		SVM20M	31	<b>Y</b>		ZFN30	27
		SVM30	31	Y120	7	ZFN5	27
		SVM30M	31	Y2	7	ZFNP1	27
		SVM5M	31	Y20	7	ZFNP10	27
		SW2	20	Y250	7	ZFNP3	27
		SW20	20	Y4	7	ZFNP5	27
		SW20S	20	Y400	12 • 16	ZS7P	5
		SW2S	20	Y6	7	ZS7PS	6
		SW4	20	Y600	12 • 16	ZT7S	6
		SW4S	20	Y6A	7		
		SW5	20	Y6J	7	<b>#</b>	
		SW5S	20	Y75-185	65	#40	44
		SX10	87	Y75-225	65	#60	44
		SX15	88	Y800	12 • 16	#100	44
		SX20	87	Y817P	7		
		SX25	88	Y8P	7		
		SX5	87	Y8P1	7		
		SX7	87	YL1A	92		
		SY7P	7				
				<b>T</b>			
				TRF100D	34 • 77		
<b>S</b>							
S0	48						
S120	5						
S120S	5						